

SUBJECT TO CONTRACT / CONTRACT DENIED

HUTCHISON 3G IRELAND LIMITED

AND

[•]

**WHOLESALE SERVICES AGREEMENT
NATIONAL BROADBAND SCHEME**

Copyright 2008, Hutchison 3G Ireland Limited

All rights reserved. This confidential document contains proprietary information that may be used for the purposes of this Agreement only. No part of this information may be disclosed to others, nor may it be reproduced, copied or transmitted in any form or by any means, electronic, mechanical, or otherwise without prior written permission from Hutchison 3G Ireland Limited and upon whose request this document must be returned.

CONTENTS

Page No

1	DEFINITIONS	1
2	TERM.....	7
3	PRE-LAUNCH OBLIGATIONS	7
4	SERVICES.....	7
5	OBLIGATIONS OF H3G	8
6	RIGHTS AND OBLIGATIONS OF THE COMPANY	9
7	CUSTOMER TERMS AND CONTRACTS	11
8	USIMS AND BROADBAND DEVICES	12
9	CHARGES	13
10	INVOICING AND PAYMENT	14
11	RESELLERS.....	14
12	TRADE MARKS AND MARKETING.....	15
13	TERMINATION	15
14	CONSEQUENCES OF TERMINATION	16
15	WARRANTIES AND INDEMNITIES.....	17
16	LIABILITY	18
17	USE OF THE NETWORK.....	19
18	DISRUPTION EVENTS	19
19	ASSISTANCE WITH LAW ENFORCEMENT AGENCIES AND AUTHORITIES	20
20	CONTRACT MANAGEMENT	20
21	SUB-CONTRACTORS	21
22	STAFF.....	21
23	CONFIDENTIALITY.....	22
24	DATA PROTECTION.....	23
25	INSURANCE.....	23
26	COMPLIANCE WITH LAWS	23
27	FORCE MAJEURE	24
28	NOTICES.....	24
29	ASSIGNMENT	25
30	DISPUTES.....	25
31	COSTS.....	25
32	NO WAIVER	25
33	SEVERABILITY	25
34	ENTIRE AGREEMENT	26
35	SURVIVAL	26
36	RELATIONSHIP OF THE PARTIES.....	26

37	FURTHER ASSURANCES.....	26
38	VARIATION	26
39	GOVERNING LAW AND JURISDICTION.....	26
40	COUNTERPARTS.....	26
Schedule 1.....		28
	SERVICES AND USAGE PROFILE.....	28
Schedule 2.....		29
	CHARGES	29
Schedule 3.....		30
	COMPULSORY CUSTOMER TERMS.....	30
Schedule 4.....		31
	CUSTOMER PROOF REQUIREMENTS	31
Schedule 5.....		40
	WHOLESALE END USER END TO END PROCESS DEFINITION	40
Schedule 6.....		90
	USIMs	90
Schedule 7.....		95
	BROADBAND DETAIL RECORDS	95
Schedule 8.....		97
	NATIONAL BROADBAND SCHEME COVERAGE AREA	97
Schedule 9.....		129
	SERVICE LEVEL AGREEMENT	129
SCHEDULE 10.....		133
	CREDIT CHECK PROCEDURES	133

THIS AGREEMENT is made the _____ day of _____ 200[●]

BETWEEN:

- (1) **HUTCHISON 3G IRELAND LIMITED** a company incorporated in Ireland (registered no. 316982), whose registered office is at 3rd Floor, 6-10 Suffolk Street, Dublin 2, Ireland (hereafter referred to as **"H3G"**) ; and
- (2) [●] a company incorporated in [●] (registered no. [●]), whose registered office is at [●] (hereafter referred to as the **"Company"**)

(each a **"party"** and together, the **"parties"**).

WHEREAS:

- (A) H3G is engaged in the business of operating a third generation mobile telecommunications network.
- (B) The Company intends to launch, promote and develop its own mobile broadband service and to market the same through its Resellers in Ireland with the purpose of providing a broadband service to Customers and End-Users based in the National Broadband Scheme Coverage Areas.
- (C) The Company wishes H3G to provide and H3G has agreed to provide the Services to the Company subject to the terms and conditions of this Agreement.
- (D) This Agreement sets out the agreement between the parties for the provision and distribution of the Services.
- (E) The parties acknowledge that the Services to be provided by H3G to the Company is in the National Broadband Scheme Coverage Areas only and that the Charges have been agreed on this basis (all as hereinafter defined).

NOW IT IS HEREBY AGREED as follows:

1 DEFINITIONS

1.1 In this Agreement:

- "Account Manager"** has the meaning described in Clause 19.1;
- "Activate"** means the activation of a USIM to enable a Broadband Device to receive the Services, and "Activated" and "Activation" have corresponding meanings;
- "Active End-User"** means an End-User that has generated revenue to H3G from the use of Customer Services in the three months period ending on the first day of a month;
- "Active USIM"** means the USIM which is Activated to receive the Services;
- "Additional Period"** means a period of 12 calendar months;
- "Agreement"** means this written agreement, including the Schedules;
- "Authority"** shall mean a governmental body that is authorised to issue a valid and lawful request or warrant for Legal Interception;
- "Authorised Undertaking"** means a person (or persons) who are authorised to provide an electronic communications network or an electronic communications service pursuant to

Regulation 4 of the Authorisation Regulations (as amended) or who are exempt thereunder from the requirement to obtain an authorisation;

“Company Affiliate” means (i) any person which is Controlled directly or indirectly by the Company; (ii) any person which Controls the Company; or (iii) any person under common Control with the Company;

“Best Industry Practice” means the exercise of that degree of skill, care, diligence, prudence and judgement which would reasonably and ordinarily be expected of a skilled and experienced person engaged to carry out services similar to the Services and under the same or similar circumstances or conditions seeking in good faith to comply with its contractual obligations, complying with all applicable Laws;

“BDR” means a detailed record of chargeable events relating to use of the Services by End-Users, in the form set out in schedule 7 or as otherwise varied in accordance this Agreement;

“Billing Report” means a report detailing the total aggregate usage for all Customers in the previous month in respect of which H3G has provided Services;

“Broadband Device” means a device (including but not limited to a data card, USB card or Nextivity Unit) or a broadband device that is compatible with a USIM and is approved by H3G for use on the Network for the purposes of accessing Services;

“Business Day” means any day that commercial banks are open for business in Dublin, Ireland but excluding Saturday and Sunday;

“Charges” means the fees and charges including the usage charges payable by the Company to H3G as set out in Schedule 2 as amended in accordance with this Agreement.

“Commencement Date” means the date of last signature of this Agreement;

“Commercial Launch Date” means the date on which the Company commences provision of Customer Service to Customers or to Resellers on a commercial basis, on a date to be agreed by the parties;

“ComReg” shall mean the Commission for Communications Regulation;

“Compulsory Customer Terms” means the terms and conditions to be inserted into the Customer Contract as set out in Schedule 3;

“Confidential Information” means all information:

- (a) disclosed (by whatever means, directly or indirectly) by H3G or an H3G Affiliate to the Company or by the Company to H3G, whether before or after the Commencement Date, including without limitation any information and data relating to existing or potential Customers, technical and business information, inventions or products, research and development, production, manufacturing and engineering processes, employees or officers, lists or requirements, price lists or pricing structures, marketing and sales information, business plans or dealings, financial information or plans, trade secrets, designs, product lines of the person making the disclosure or its group undertakings, sub contractors, suppliers, Customers, clients or other contacts;
- (b) which relates to the provision or use of the Services to or by H3G or an H3G Affiliate;
- (c) the existence and terms of this Agreement; and
- (d) information relating to H3G or an H3G Affiliate or its sub-contractors, suppliers, customers, clients or other contacts which is disclosed to, or processed or otherwise handled by, the Company, its contractors, agents and/or Resellers in the course of the

performance of the Company's obligations under this Agreement is deemed to be of a 'confidential nature';

“Control” or “Controlled” means in relation to a company, that a company shall be treated as “controlled” by another if that other company (whether directly or indirectly and whether by ownership of share capital, possession of voting power, contract or otherwise) holds a voting interest in aggregate of more than 50% of the outstanding voting interests of that company; has the power to appoint, elect and/or remove the majority of the members of the board of directors or other similar governing body of that company; or otherwise has the power to control the affairs, management and policies of that company;

“Core Services” means those Services listed in Schedule 1 as core services or otherwise agreed by the parties from time to time to be core services;

“Credit Check Procedures” means the procedure as set out in Schedule 10;

“Customer” means any person, being either an individual or corporate entity, to whom the Company or any Reseller provides Customer Services and who is a Fixed Resident or Fixed Business in the National Broadband Scheme Coverage Areas;

“Customer Contract” means the terms and conditions on which the Company or a Reseller provides Customer Services to a Customer, which must incorporate the Compulsory Customer Terms;

“Customer Service” means the service provided by the Company or Resellers to Customers including the re-sale of Services;

“Deactivate” means to disable an Activated USIM from being able to receive the Services and “Deactivated” and “Deactivation” have corresponding meanings;

“Electoral Divisions” means the smallest administrative area for which population statistics are published (formerly called District Electoral Division) as referenced in Schedule 8;

“End User” means a person that uses a Service provided by a Reseller or by the Company to a Customer (whether with the permission of the Customer or otherwise) and includes an individual where the Customer is a corporation or organisation;

“Fixed Residences and Fixed Businesses” means all buildings in the Coverage Areas that have a postal address which is listed in the “Buildings” table of the GeoDirectory Database save where such buildings are classified as “invalid”, “derelict” or “under construction” and a “Fixed Residence” means a residence which falls within the definition of “Fixed Residences and Fixed Businesses” and a “Fixed Business” means a business premises which falls within the definition of “Fixed Residences and Fixed Businesses”;

“Flex File” means a combination of program functions including IP addresses that are linked together to ensure the Broadband Device functions on the Network;

“Force Majeure Event” means the occurrence after the Commencement Date of an event beyond the control of the Affected Party that frustrates or renders impossible (but not merely more expensive) the performance of the obligations of the Affected Party including any of the following:

- (a) official or unofficial strike, lock-out, labour dispute, go-slow or other industrial action generally affecting the electronic communications industry in Ireland or a significant sector thereof where any such event is ongoing for a period in excess of five (5) Business Days;
- (b) war, riot, civil commotion, act of terrorism, military operations, armed conflict arising in or affecting Ireland or the presence of an unexploded bomb or other live and dangerous ammunition in any area in which the Services are to be carried out;

- (c) act of God, earthquake, lightning, fire, explosion, flood, storm, tempest, exceptionally adverse weather conditions, bursting or overflowing of water tanks, apparatus or pipes, nuclear, chemical, radioactive or biological contamination arising in or affecting Ireland;
- (d) any blockage or embargo or failure or shortage of power, fuel, materials or transport arising in or affecting Ireland generally, where any such event is ongoing for a period in excess of (i) in the case of a blockage, embargo, failure or shortage with respect to power, two (2) Business Days and (ii) in the case of a blockage, embargo, failure or shortage with respect to fuel or transport, five (5) Business Days;
- (e) restrictions due to the spread or possible spread of disease among humans or animals; and
- (f) a failure by a party to carry out its obligations pursuant to this Agreement (other than a payment obligation) where those obligations are wholly or mainly dependent on the performance by the other Party of its obligations pursuant to this Agreement and that other Party is prevented from performing its obligations by reason of any of the circumstances addressed above; **PROVIDED THAT:**
 - (i) the circumstances could not have been prevented or overcome by the exercise by the Affected Party of the standard of a reasonable and prudent operator of the Services;
 - (ii) a change in Law shall not be deemed to be a Force Majeure Event;

“H3G Affiliate(s)” means (i) HWL; (ii) any person which is Controlled directly or indirectly by HWL; or (iii) any company in which HWL holds directly or indirectly 25% or more of the shares or voting power;

“HWL” means Hutchison Whampoa Limited, a company incorporated under the laws of Hong Kong;

“Insolvency Event” means a party is or is deemed unable to pay its debts as they fall due; or a receiver is appointed to the whole or any part of the undertaking, business or assets of a party; or a petition is presented applying to the courts for the winding-up of a party or for an examination order to be made in relation to a party; or a resolution is passed for the winding-up or dissolution of a party; or a party enters into any voluntary arrangement with its creditors or ceases or threatens to cease to carry on its business; or a party is declared bankrupt; or anything analogous to such events in any other jurisdiction;

“Initial Term” means a period of 5 years and 8 months beginning from the Commencement Date;

“Intellectual Property Rights” means all intellectual property rights, including patents, registered designs, trade marks and service marks (whether registered or not), rights in the nature of unfair competition rights, copyright, database rights, design rights and all similar property rights including those subsisting (in any part of the world) in inventions, designs, drawings, performances, computer programs, semiconductor topographies, confidential information, business names, goodwill and the style and presentation of goods and services and applications and the right to apply for protection or the renewal of protection of any of the above rights anywhere in the world;

“Interface” means the internet based application protocol interface that allows the Company to request, and H3G to perform, actions to enable the provision of the Services;

“Laws” means any and all constitutions, acts, statutes (including all employment, health and safety and equality laws (including the Equal Status Act 2000 (as amended) and the Employment Equality Act 1998 (as amended)), law, by-law, rules, codes (whether binding or

voluntary), regulations, rules, decisions, directives, orders, guidelines, recommendations, policies, standards and/or conditions having effect in Ireland or any relevant part thereof including any final judgement or order of any court of competent jurisdiction and further including, any enforceable community right within the meaning of Section 2 of the European Communities Act 1972; and any applicable judgment of a relevant court of law which is a binding precedent, in each case in force at any time in Ireland or any other relevant jurisdiction, and any Regulatory Requirement;

“Legal Interception” shall mean the execution of an order by an Authority to tap a Customer on the Network;

“Licence” means the individual licence granted to H3G by ComReg and such replacement and/or additional licences under which H3G may be authorised to provide mobile communications services from time to time;

“National Broadband Scheme Coverage Area(s)” means the geographical areas described in terms of Electoral Divisions as set out in Schedule 8;

“NBS Logo” means any trade mark, trade name, logo or brand used now or in the future in respect of the Services, including without limitation the use of the word “NBS” or “National Broadband Scheme” as a trade mark, logo or brand name;

“Network” means the mobile communication network used by H3G to provide the Services in the National Broadband Scheme Coverage Areas;

“Non-Core Services” means all services which are not Core Services and which are agreed by the parties from time to time;

“Non Discriminatory Basis” means, in respect of the provision by H3G of Services, an obligation to do so according to the equivalent timeframes, technical specifications, operational specifications (including access to support systems) and performance standards in accordance with which H3G supplies these services and capabilities to itself and to its own retail customers in the National Broadband Scheme Area and to other Authorised Undertakings;

“Project” means the rollout of broadband services to the National Broadband Scheme Coverage Areas pursuant to the agreement between the Department of Communications, Energy and Natural Resources and H3G.

“Persistent breach” means more than three breaches of this Agreement in any six month rolling period from the Commencement Date, the cumulative effect of such breaches being, in H3G’s reasonable opinion considering the nature of the breach and its effect in aggregate, is sufficient to justify the inference that the Company in breach would continue to deliver a substandard performance in relation to its obligations under or in connection with this Agreement;

“Project Plan” means the plan in relation to the provision of the Services as set out in Schedule 11 sample project plan the specific terms of which are to be agreed with the Company;

“Regulator” means any applicable government or regulatory authority, inclusive of but not limited to ComReg;

“Regulatory Requirement” means any applicable guidance, direction, code of practice, condition, licence, self-regulation, determination or regulations including those issued by any Regulator and those issued by any mobile operator industry group, compliance with which is mandatory or forms part of Best Industry Practice;

“Reseller” means any reseller appointed by the Company pursuant to Clause 11 to resell the Services to Customers;

“Services” means the broadband services within the National Broadband Scheme Coverage Areas to be made available by H3G to the Company via the Network as more particularly described in Schedule 1 (as may be amended from time to time);

“Service Level Agreement” means in relation to any of the Services, the performance requirements set out in Schedule 9 including the targets set out therein and any amendments to the performance requirements agreed in accordance with the Change Control Procedure;

“Staff” means all employees, consultants, agents or sub-contractors, contractors (and the employees, consultants and agents thereof) whether present or future;

“Term” means the term of this Agreement as set out in Clause 2;

“Third Party Operator” the operator of a mobile telecommunications network other than H3G;

“UMTS” means Universal Mobile Telecommunications Service;

“Usage Profile” means the permitted parameters for Network traffic set out in Schedule 1;

“USIM” means a universal subscriber identity module card;

“USIM Charge” means the charge payable by the Company to H3G for the provision of each USIM which is sold exclusive of the Broadband Device as set out in Schedule 2;

“Wholesale One-Off Charge” means the charge payable for each Broadband Device ordered by the Company, as set out in Schedule 2

“Wholesale Tariff” means the monthly charge payable by the Company for each Active USIM, as set out in Schedule 2.

“Wholesale Services Ancillary Charges” means the charge payable by the Company for each Mbit downloaded by an End User, as set out in Schedule 2.

- 1.2 Where the context so admits or requires words denoting the singular include the plural and vice versa and words denoting any gender include all genders.
- 1.3 Clause headings are purely for ease of reference and do not form part of or affect the interpretation of this Agreement.
- 1.4 References to this Agreement mean this Agreement and the Schedules.
- 1.5 References to Clauses, Sections and Schedules are to clauses of this Agreement and Sections of the Schedules to this Agreement.
- 1.6 References to each party herein include references to its successors in title, permitted assigns and novatees.
- 1.7 References to “including”, “includes” and “in particular” are illustrative, none of them shall limit the sense of the words preceding it and each of them shall be deemed to incorporate the expression “without limitation”. “Other” and “otherwise” are also illustrative and shall not limit the sense of the words preceding them.
- 1.8 If there is a conflict or inconsistency between the Clauses in the body of this Agreement and Sections of the Schedules, the Clauses shall prevail.
- 1.9 Any reference to any statutory provision, or to any order or regulation shall be construed as a reference to that provision, order or regulation as extended, modified, replaced or re-enacted

from time to time (whether before or after the date of this Agreement) and all regulations and orders from time to time made thereunder or deriving validity therefrom.

2 TERM

- 2.1 The parties hereby acknowledge that it is a pre-condition of the commencement and performance of the terms and conditions of this Agreement and commencement of the Services that the Company has proved sufficient evidence to H3G's satisfaction that the Company is an Authorised Undertaking.
- 2.2 Subject to Clause 2.1, the Term of this Agreement shall begin on the Commencement Date and continues for the Initial Term unless renewed or terminated earlier in accordance with an express provision of this Agreement.
- 2.3 This Agreement shall, subject to termination in accordance with its terms, be automatically renewed on and from the expiry of the Initial Term for an Additional Period, and on and from expiry of that Additional Period for a further Additional Period commencing on the expiry of the first Additional Period. Either party may terminate the Agreement at the end of the Initial Term or any Additional Period, by giving written notice to the other party not less than 6 months (or other period as may be agreed by the parties) prior to the end of the Initial Term or the relevant Additional Period, as the case may be.

3 PRE-LAUNCH OBLIGATIONS

- 3.1 H3G will use its reasonable endeavours to begin, or be able to begin, providing the Services to the Company by a date agreed by the parties.
- 3.2 Notwithstanding any other Clause in this Agreement, H3G will not be required to commence provision of the Services to the Company unless and until such time as the Company has;
- 3.2.1 provide evidence to H3G's satisfaction that it is an Authorised Undertaking; and
- 3.2.2 passed, to H3G's reasonable satisfaction, any mutually agreed tests in connection with the launch of the Customer Service; and
- 3.2.3 satisfied H3G's standard Credit Check Procedures in full, as determined at the sole discretion of H3G, acting reasonably.

4 SERVICES

- 4.1 Subject to the terms and conditions of this Agreement, H3G shall provide the Services to the Company for resale by the Company to Customers or to Resellers and onward resale by Resellers to Customers upon request on and from the Commercial Launch Date.
- 4.2 The Company acknowledges and agrees that it is a condition of this Agreement that the Services may only be sold to Customers and warrants that it shall only offer the Services to Customers.
- 4.3 The Company acknowledges and agrees that the Services or parts thereof may not be available from time to time as a result of a number of factors, including but not limited to capacity constraints, electromagnetic interference, adverse weather conditions, excessive use of the Network, equipment failure or maintenance activities and to that such non-availability affects Customers and will use its reasonable endeavours to notify the Company prior to any such suspension, but the Company will be treated on a Non-Discriminatory Basis in respect of such matters.
- 4.4 The Services provided by H3G will be available within the National Broadband Scheme Coverage Areas only. The Company accepts that the quality and availability of the Services may be affected by Force Majeure Events. H3G shall have no liability to the Company or its Customers, Resellers or End-Users in connection with any such adverse effect on the quality

and availability of the Services, but subject to Clause 27 (Force Majeure) the Company will be treated on a Non-Discriminatory Basis in respect of such matters.

- 4.5 H3G may at any time and without liability modify, expand, improve, maintain, vary or repair the Network or vary Network capacity even if this requires suspension of the operation or provision of the Services. H3G shall endeavour to keep such disruption to a minimum and will use reasonable endeavours to notify the Company prior to any such suspension, but the Company will be treated on a Non-Discriminatory Basis in respect of such matters.
- 4.6 If H3G is required to effect any unplanned emergency changes to the Services, it shall inform the Company of such change as soon as reasonably practicable. Where practicable, the emergency changes shall be reversed once the emergency has passed.
- 4.7 Subject to any obligations of confidentiality owed or may be owned from time to time by H3G to third parties, H3G will provide the Company with information from time to time relating to new services or changes to the Services on a Non-Discriminatory Basis, and which at a minimum will cover any planned changes in the Services.
- 4.8 The parties hereby acknowledge that each USIM shall only be Activated to access the Network and shall be limited to use within the National Broadband Scheme Coverage Areas.
- 4.9 H3G may from time to time and at any time during the Term offer new services to the Company or vary the Network or Services. H3G shall have the right to deny access to the Interface, the Network or to any Third Party Operator's network to any broadband device or equipment if H3G suspects fraudulent, criminal or illegal activities, or any activities described in Schedule 5 are being carried out, or are likely to be carried out, via that broadband device or equipment;
- 4.10 Notwithstanding Clause 5.3, H3G may from time to time and at any time during the Term upgrade the BDR format, any part of the Interface or an interface or any software which is remotely or otherwise accessed by the Company for the purpose of obtaining the Services. The Company shall at its own cost and risk make all necessary changes to its systems and processes to support such changes. H3G will give reasonable notice prior to any upgrade to the BDR format or the Interface if H3G is aware that such upgrade would require the Company to make changes to its systems and processes in order to support such upgrade. H3G to provide such notice to Authorised Undertaking on a Non-Discriminatory Basis. H3G will use its reasonable endeavours to retain backwards compatibility with existing BDR formats and the existing Interface when upgrading BDR formats and the Interface.
- 4.11 The parties acknowledge that any new services to be offered by H3G pursuant to Clause 4.9 which becomes a Service, may be subject to terms in addition to those set out in this Agreement and H3G may impose additional reasonable terms which terms shall be deemed to be terms of this Agreement in relation to the supply of those new Services with as much notice as practicable. Any such additional terms will be applied on a Non-Discriminatory Basis.

4.12 H3G expressly disclaims any warranties that the Services will be uninterrupted or error free.

5 OBLIGATIONS OF H3G

- 5.1 H3G will provide the Services to the Company from the Commercial Launch Date until the expiry or early termination of the Term in accordance with the terms and conditions of this Agreement, including, without limitation, the procedures referred to in Schedule 5.
- 5.2 H3G will use its reasonable endeavours to:
 - 5.2.1 discharge its obligations pursuant to this Agreement with reasonable skill, care and diligence;
 - 5.2.2 maintain, on a Non-Discriminatory Basis, the availability of Services to the Company throughout the National Broadband Scheme Coverage Area;

- 5.2.3 provide fraud detection and prevention information as described in Schedule 5, provided that H3G shall have no liability in respect of such information, nor in respect of any failure or omission to provide any such information; and
- 5.2.4 comply with the procedures referred to in Schedule 5.
- 5.3 BDRs will be made available by H3G in a format determined by H3G at its sole discretion.
- 5.4 H3G shall use its reasonable endeavours to ensure that such BDRs are regularly updated in intervals of no less than 30 minutes in respect of all Services relating to transactions involving only telecommunications networks. Such BDRs are not produced in “real time” and BDRs may not contain a full record of all Services that have been supplied up to the time of download of the BDR.
- 5.5 Notwithstanding any other provision in this Agreement, H3G shall have no obligation to the Company or any other person beyond the exercise of the reasonable skill, care of a competent telecommunications operator in performing its obligations under this Agreement.
- 5.6 H3G shall use its reasonable endeavours to provide the Services in accordance with the following:
 - 5.6.1 the “Fault Resolution Best Endeavours Timelines” set out in Schedule 5;
 - 5.6.2 the Service Level Agreement; and
 - 5.6.3 provision of the Interface in accordance with Schedule 5 provided that the Interface will not be considered to be unavailable during any planned maintenance or for any outage caused by or attributed to the fault or negligence of the Company or any Reseller.

In the absence of proof to the contrary, measurement of the performance levels pursuant to this Agreement shall be taken from H3G's records.

6 RIGHTS AND OBLIGATIONS OF THE COMPANY

- 6.1 The Company will provide sufficient resources to develop, and maintain at its own cost, the necessary systems, hardware and software to access the Interface for the purposes of fulfilling its obligations under this Agreement.
- 6.2 For the avoidance of doubt, the Company will be responsible for all activities required to provide the Customer Services which are not expressly stated to be the responsibility of H3G under this Agreement, including but not limited to:
 - 6.2.1 those activities relating to Activation, Deactivation, suspension of Customer Services to Customers and End-Users that are not stated in the Schedules to be the responsibility of H3G;
 - 6.2.2 Customer marketing and advertising of Services;
 - 6.2.3 packaging, distribution and sales of Broadband Devices and USIMs to Customers;
 - 6.2.4 Customer billing and debt collection;
 - 6.2.5 detection of fraud, notwithstanding that the Company may use the systems and information provided by H3G; and
 - 6.2.6 Customer, Reseller and End-User support.
- 6.3 The Company acknowledges that:

- 6.3.1 H3G does not provide the Services on an exclusive basis to the Company and may appoint other persons and/or companies to be data mobile virtual network operators or wholesalers or resellers of all or some of the Services; and
- 6.3.2 H3G may compete with the Company's and other distributors of the Services.
- 6.4 The Company shall not, without the prior written consent of H3G allow any Company Affiliate, or company associated with the Company, save where they are a Reseller, whether by means of joint venture, partnership or otherwise to access the Services provided under this Agreement.
- 6.5 The Company hereby warrants and undertakes that it:
- 6.5.1 it has full capacity and authority to enter into this Agreement and that it has or will obtain prior to the Commencement Date, any necessary licences, consents, and permits required of it for the performance of its obligations under this Agreement;
- 6.5.1 holds and shall maintain in full force and effect for the duration of this Agreement all necessary licenses or approvals to perform its obligations according to the terms of this Agreement;
- 6.5.2 shall discharge its obligations pursuant to this Agreement with all reasonable skill, care and diligence;
- 6.5.3 shall only use the Services in accordance with the terms of this Agreement and for the sole purpose of providing Customer Services;
- 6.5.4 shall provide to H3G, on a monthly basis and in the manner and form required by H3G, a rolling 12 month forecast of the anticipated volume of the following:
- (a) the total number of new End-Users activated on the Network;
 - (b) the total number of Active End-Users; and
 - (c) such other forecast information as is reasonably required by H3G from time to time for the sole purpose of forecasting For the avoidance of doubt, only the H3G Wholesale Team will have access to the Company's forecast information as provided under this Clause 6.5.4;
- 6.5.5 shall comply with the business processes described in Schedule 5, as may be amended by H3G from time to time (provided that such processes will only be amended by H3G on a Non-Discriminatory Basis and upon the giving of reasonable notice of amendment);
- 6.5.6 shall only sell Broadband Devices to Resellers and Customers;
- 6.5.7 shall only sell USIMs to Resellers and Customers for use in Broadband Devices;
- 6.5.8 shall assist H3G in its compliance with any request by the DCENR for information relating to the Project; and
- 6.5.9 shall include an obligation in each Customer Contract, and procure that each proposed contract between a Reseller and a Customer includes an obligation, which requires the Customer to provide to the Company, Reseller and where necessary H3G with the required Customer proofs as set out in Schedule 4.
- 6.6 The Company may only appoint Resellers in accordance with Clause 11.
- 6.7 The Company shall comply with all Laws, regulations, standards and codes applicable to this Agreement including the Customer Service. In particular, the Company shall:

- 6.7.1 not represent or pass-off that it is H3G in supplying services to Customers;
- 6.7.2 not represent that it is authorised to act on behalf of H3G;
- 6.7.3 comply with all lawful and reasonable directions issued by H3G reasonably necessary to assist it in complying with its legal or regulatory obligations (including, but not limited to, its obligations under the Data Protection Acts 1988 and 2003, the European Communities (Electronic Communications Networks and Services) (Data Protection and Privacy) Regulations 2003, in particular directions relating to:
 - (a) providing information to the Gardai Siochana and other law enforcement agencies;
 - (b) the provision of emergency services; and
- 6.7.4 co-operate with H3G and comply with all lawful and reasonable directions issued by H3G in relation to number management and procedures relating to transferability or portability.

7 CUSTOMER TERMS AND CONTRACTS

- 7.1 The Company shall procure that with regard to all Active USIMS it shall:
 - 7.1.1 ensure that all Customer Contracts include the Compulsory Customer Terms and include an obligation on the Customer to provide Customer proofs as described in Schedule 4;
 - 7.1.2 only resupply the Services to persons who have agreed to be legally bound by a Customer Contract;
 - 7.1.3 enforce Compulsory Customer Terms where not to do so could have a detrimental effect on H3G; and
 - 7.1.4 provide H3G with a copy of the standard form Customer Contracts at any time on reasonable request from H3G;
 - 7.1.5 notwithstanding Clause 7.1.1, provide H3G with evidence that each Customer is resident or has their principal place of business in the National Broadband Scheme Coverage Areas in the form of a proof of address, as set out in Schedule 4, together with the USIM details of each Customer. This information must be supplied to H3G no later than 1 calendar month of the Customer entering into the Customer Contract.
- 7.2 H3G excludes any express or implied warranty that the Compulsory Customer Terms will protect the Company or Resellers from claims made by Customers or End-Users. H3G does not and shall not warrant that the USIMs will be resistant to all possible attacks and shall not incur, and disclaims, any liability in this respect. Even if each USIM is compliant with current security standards in force on the date of their design, security mechanisms' resistance necessarily evolves according to the state of the art in security and notably under the emergence of new attacks.
- 7.3 If the Company or any Reseller is required to make amendments to the Compulsory Customer Terms as a result of a change in Law or regulation, the Company shall, on behalf of itself and the Resellers, inform H3G of such changes and shall ensure that such amendments are only to the extent required by that change in Law or regulation.
- 7.4 H3G acknowledges and agrees that:
 - 7.4.1 subject to the terms and conditions of this Agreement, the Company will have complete discretion as to the manner in which it prices, promotes and distributes services and products (including the Services) to Resellers or Customers and likewise

Reseller will have complete discretion as to the manner in which it prices promotes and distributes services and products (including the Customer Service) to Customers; and

7.4.2 the contracts between the Company and Resellers or Customers and the contracts between Resellers and Customers will not involve H3G and H3G will have no rights or obligations under any such contracts other than as provided in the Compulsory Customer Terms.

8 USIMS AND BROADBAND DEVICES

8.1 During the Term, the Company may only order USIMs for itself or Resellers or Customers from H3G for the purposes of the provision of the Services. H3G shall be entitled to (i) a Wholesale Tariff (ii) a Wholesale One-off Charge for each Broadband Device ordered by the Company and (iii) the Wholesale Service Ancillary Charges.

8.2 All orders for USIMs and Broadband Devices (together the “**Devices**”) shall be placed in accordance with the following ordering procedures and rules:

8.2.1 the Company shall from time to time raise a purchase order and submit it to H3G's Account Manager;

8.2.2 the Company must submit a separate purchase order for each order of the Devices;

8.2.3 each purchase order must be for a minimum order of 200 USIMs (unless otherwise mutually agreed between the parties);

8.2.4 each purchase order must state the approved Charges for Devices as specified in Schedule 2 or as otherwise provided in this Agreement;

8.2.5 each purchase order must state a single delivery address for the delivery of all Devices in that order; and

8.2.6 otherwise as provided in the terms of USIM purchase as set out in [Schedule 6 Part B].

8.3 Any Devices ordered by the Company from H3G will be subject to the terms and conditions of USIM purchase set out in Schedule 6 Part B. Title to Devices shall pass to the Company on payment to H3G for each respective Devices. Risk in the Devices shall pass to the Company on delivery.

8.4 The Company acknowledges that H3G is procuring the Devices from a third party supplier at the request of the Company. H3G will only provide the Company with the services relating to the procurement of Devices expressly stated in this Agreement (including in Schedule 6 Part B). Other than as expressly stated in this Agreement (including in **Schedule 6 Part B**), H3G is not required to provide the Company with any other Devices procurement services.

8.5 H3G will not be liable for any loss or damage whether direct or indirect, consequential or contingent and whether foreseeable or not howsoever caused (except for death or personal injury resulting from the proved negligence of H3G) arising out of the purchase, possession, sale, rental, or use by the Company or its Resellers or Customers of Devices and in particular hereby disclaims any and all other terms conditions and warranties, express or implied whether statutory, arising out of trade usage or otherwise.

8.6 The Company acknowledges that Devices contain software and information that is proprietary to H3G and its licensors and the Company shall not tamper with any Devices and must immediately notify H3G if any Devices within its or Resellers' possession is tampered with.

8.7 In relation to the Devices, H3G shall use its reasonable endeavours to transfer to the Company the benefit of any warranty given by the manufacturer to H3G.

- 8.8 The Company will provide on a monthly basis H3G with a rolling 6 months USIMs forecasts in the form as set out under Part A of Schedule 6. The Company must place orders for USIMs with H3G within the following parameters as compared to each 6 month forecast:
- 8.8.1 months 1 and 2 of each 6 month period: no variance;
 - 8.8.2 months 3 and 4 of each 6 month period: +/- 50%;
 - 8.8.3 months 5 and 6 of each 6 month period: +/- 100%.
- 8.9 The Company or its Resellers may source Broadband Devices directly from the manufacturer or any other source, provided that the Company or its Resellers:
- 8.9.1 must register all Broadband Devices and USIMs on the Interface before they are sold to Customers; and
 - 8.9.2 pays its own costs of procuring and branding the Broadband Devices.
- 8.10 H3G may provide required settings to the Company from time to time which the Company shall ensure are included in the Flex File of Broadband Devices. The Company shall promptly provide to H3G upon request, the Flex File for any Broadband Device which the Company sells, supplies or otherwise permits Customers or Resellers to use.
- 8.11 If the Company wishes to sell or supply a model of broadband device to Resellers or Customers which is not a Broadband Device then prior to the Company selling such broadband device to Resellers or Customers:
- 8.11.1 H3G may agree to test the broadband device to confirm if it complies with H3G's technical specifications and any such testing of the broadband device would be dependent upon the available resources of H3G to carry out the test; and
 - 8.11.2 whether or not such broadband device is tested by H3G, such broadband device must be first approved by H3G for use on the Network.

The Company shall pay H3G's reasonable costs incurred in relation to testing, and approving, the broadband devices, such costs to be specified to the Company in advance of testing.

9 CHARGES

- 9.1 The Company shall pay H3G the Charges in Schedule 2, as amended from time to time in accordance with this Agreement. The Charges are fixed, subject only to variations provided for under the amendment of Charges in line with additional costs as provided for under Clauses 8.1, 9.2 and the variation provision under Clause 38. In the event of any variations pursuant to those provisions, Schedule 2 will be updated by H3G to account for such changes and such changes shall form part of this Agreement.
- 9.2 The Company is liable for any and all Charges incurred in respect of Activated USIMs until the USIM is Deactivated.
- 9.3 The Charges and all other payments stated in Schedule 2 are net of tax. The Company shall in addition pay to H3G the amount of any tax, duty or assessment, including but not limited to any applicable VAT, which H3G is obliged to pay and/or collect from the Company in respect of any supply under this Agreement.

10 INVOICING AND PAYMENT

- 10.1 Promptly on or after the first Business Day of each calendar month of this Agreement, H3G shall provide an invoice for Charges detailed in BDRs provided in the previous calendar month. Each invoice will be accompanied by a Billing Report, which shall be emailed to the

email address notified by the Company from time to time, for Charges which details the total aggregate usage for all Customers in relation to which H3G has provided Services.

- 10.2 The Company may only dispute invoiced Charges or the accuracy of a Billing Report by submitting a notice in writing to H3G setting out, in detail, the basis of such dispute within 15 days of the date of the invoice.
- 10.3 The Company acknowledges that usage data listed in BDRs by H3G is conclusive evidence that Services have been provided. These BDRs shall be produced using reasonable endeavours by H3G.
- 10.4 H3G may invoice the Company for USIMs on delivery of such USIMs.
- 10.5 The Company must pay all invoices within 30 days of the date of issue of an invoice.
- 10.6 If the Company does not pay any sum overdue to H3G within 7 Business Days of the due date then H3G may suspend delivery of USIMs for unfulfilled USIM orders, and if the Company fails to pay such sum within 20 Business Days of the due date then H3G may suspend the Activation of new USIMs on the Network, and if the Company fails to pay such sum within 40 Business Days of the due date then H3G may suspend delivery of the Services.
- 10.7 Unless otherwise agreed in writing, all Charges or other sums due and under or in connection with this Agreement shall be paid in full without any set-off, counterclaim or other deduction pursuant to or in connection with any other agreement between the parties.
- 10.8 Without prejudice to any other remedies that the H3G may have, if any sum payable by the Company or H3G under this Agreement is not received by H3G in cleared funds within the required payment period, the Company shall pay interest on such amount at the rate set out in the European Communities (Late Payments in Commercial Transactions) Regulations 2002 (as amended) from the relevant payment date until the date of actual payment of such funds (both dates inclusive) (such interest to accrue on a daily basis and to be compounded on a monthly basis and calculated on the basis of actual days and of a 365 day year).
- 10.9 All sums payable under this Agreement are exclusive of any VAT or other taxes or duties levied on such sums and the Company undertakes to pay and indemnify H3G in respect of any such VAT or other tax or duty properly chargeable to the Company by H3G against delivery of a valid tax invoice.
- 10.10 All payments shall be made by direct debit into the bank account specified from time to time by H3G and shall be in Euro (€).

11 RESELLERS

- 11.1 Save as expressly permitted in Clause 11.2, the Company will not authorise or appoint any reseller, retailer, distributor, agent, sub-distributor, representative or other third party to market or distribute the Services.
- 11.2 Subject to Clause 11.3, the Company may appoint Resellers provided that:
 - 11.2.1 the Company will ensure that the Resellers are bound by all obligations and restrictions set out in this Agreement applicable to Resellers and that the Reseller is obliged to incorporate the Compulsory Customer Terms in all Customer Contracts; and
 - 11.2.2 the Company shall enforce any contractual rights the Company may have with a Reseller (including termination of the relationship with the Reseller where possible).
- 11.3 The Company shall be responsible for the acts, defaults and neglects of any its agents, contractors (of any tier) servants or workmen as fully as if they were the acts, defaults, or neglects of the Company, its agents, contractors, servants or workmen.

- 11.4 H3G will not be required to have any direct contact with Resellers nor shall it have any liability whatsoever in relation to Resellers.
- 11.5 The Company shall ensure Resellers only sell and market the Services in the National Broadband Scheme Coverage Areas.
- 11.6 The Company shall ensure that its Resellers are bound by all Reseller obligations as described in this Agreement. Notwithstanding Clauses 6, 7 and 14, every act and omission of Resellers, and the Company and Resellers' contractors, agents and distributors (if any), shall be treated as a breach of this Agreement by the Company as if such act or omission would constitute a breach of this Agreement if it were caused by the Company.
- 11.7 The Company shall ensure that Resellers are not entitled to, and shall ensure that Resellers do not, authorise or appoint any reseller, retailer, distributor, agent, sub-distributor, representative or other third party to market or distribute the Services or Customer Service other than:
- 11.7.1 through use of an agent or representative who simply sells the Resellers service under the Resellers name and contract terms; or
- 11.7.2 such third party appointed by Reseller is appointed and approved as if it were a Reseller pursuant to Clauses 11.2 and 11.1, and the third party enters into a contract with the Company agreeing to be bound by all obligations of a Reseller pursuant to this Agreement.
- 11.8 The Company must ensure that all Resellers are aware of, and shall enforce compliance by Resellers with, all restrictions and obligations of Resellers pursuant to this Agreement.

12 **TRADE MARKS AND MARKETING**

- 12.1 The Company hereby acknowledges and agrees that it shall not and shall ensure that Resellers do not at any time either during the Term or after its termination, use the NBS Logo in conjunction with its own company logos save with the prior written consent of the Department of Communications, Energy and Natural Resources (the "DCENR").
- 12.2 The Company must not actively refer to H3G when describing the Services or make any public statement about H3G without H3G's prior written consent.
- 12.3 The Company must immediately inform H3G if the Company becomes aware of any improper or wrongful use or infringement of the NBS Logo.

13 **TERMINATION**

- 13.1 H3G may terminate this Agreement at any time with immediate effect by giving notice to the Company if:
- 13.1.1 the Company commits a material breach of any of the terms of this Agreement and in the case of a breach which is capable of remedy, fails to remedy the same within 30 calendar days from the date of receipt of the notice from H3G;
- 13.1.2 the Company commits a Persistent breach of any of the terms of this Agreement;
- 13.1.3 H3G Licence is terminated, revoked or expires and is not immediately renewed or replaced;
- 13.1.4 the Company ceases or threatens to cease to carry on business;
- 13.1.5 an Insolvency Event occurs in relation to the Company;

- 13.1.6 the Company provides Services to persons who are not Customers or Resellers, in terms of this Agreement; or
- 13.2 The Company may terminate this Agreement at any time with immediate effect by giving notice to H3G if
 - 13.2.1 if H3G ceases or threatens to cease to carry on business; or
 - 13.2.2 an Insolvency Event occurs in relation to H3G;
 - 13.2.3 H3G commits a Persistent breach of this Agreement; or
 - 13.2.4 H3G commits a material breach of any of the terms of this Agreement and in the case of a breach which is capable of remedy, fails to remedy the same within 30 calendar days from the date of receipt of the notice from the Company;
- 13.3 Either Party may terminate this Agreement for convenience by giving not less than six (6) months written notice to the other Party that it does not wish this Agreement to continue beyond the expiry of the Initial Term or the then running Additional Term, as the case may be, in which case this Agreement shall terminate on expiry of the Initial Term or the relevant Additional Term.
- 13.4 Each party must promptly notify the other if an Insolvency Event occurs in respect of that party.
- 13.5 For the avoidance of doubt, breach of Clause 4.1 shall be deemed to be a material breach which is not capable of remedy.

14 CONSEQUENCES OF TERMINATION

- 14.1 Termination or expiry of this Agreement shall not affect the rights and obligations of the Parties accruing prior to the date of termination or expiry.
- 14.2 Any termination of this Agreement pursuant to this Clause 6 shall be without prejudice to any other rights or remedies a Party may be entitled to hereunder or at law and shall not affect any accrued rights or liabilities of either Party nor the coming into or continuance in force of any provision hereof which is expressly or by implication intended to come into or continue in force on or after such termination
- 14.3 Upon lawful termination or expiry of this Agreement:
 - 14.3.1 H3G shall immediately cease providing the Services;
 - 14.3.2 all sums due from the Company shall become immediately payable to H3G;
 - 14.3.3 all undisputed sums due from H3G shall become immediately payable to the Company;
 - 14.3.4 the Company shall procure that each Reseller forthwith ceases to resell Services or to have access to the Network;
 - 14.3.5 all items which belong to H3G and which were delivered to the Company and/or Resellers under this Agreement will be returned to H3G or destroyed upon the request of H3G;
 - 14.3.6 all items which belong to the Company and which were delivered under this Agreement will be returned to Company or destroyed;
 - 14.3.7 all USIMs allocated to the Company (if any) shall revert to H3G; and

- 14.3.8 each Party shall forthwith return any material containing Confidential Information supplied by the other or shall destroy such material if it also contains its own Confidential Information provided that both Parties shall be entitled to keep one copy of this Agreement as a record of their obligations under this Agreement.
- 14.4 Upon termination of this Agreement, the Company shall be required to take delivery of, and pay to H3G the respective Charges incurred by the Company prior to such termination. If H3G terminates the Agreement pursuant to Clause 13.1 the Company shall pay to H3G any reasonable costs incurred by H3G as a result of H3G relying on the Company USIM forecasts provided pursuant to Clause 8.9.
- 15 WARRANTIES AND INDEMNITIES**
- 15.1 Each party hereby warrants to the other that:
- 15.1.1 it is duly incorporated under the jurisdiction of its incorporation, with all requisite corporate power and authority to own, lease and operate its assets and carry on its business as now being operated and conducted; and
- 15.1.2 the entering into and performance of its obligations hereunder will have been duly authorised by all necessary corporate action on its part.
- 15.2 Except as set out in this Agreement, all conditions, warranties and representations, expressed or implied by:
- 15.2.1 statute;
- 15.2.2 common law; or
- 15.2.3 otherwise, are excluded.
- 15.3 Neither party shall use the other party's name in any action or claim, including without limitation any admission of liability by the other party, without that party's prior written consent.
- 15.4 The Company will defend, indemnify, keep indemnified and hold harmless H3G and its directors, officers, employees and agents ("**Indemnified Parties**") from and against any liabilities, losses, damages, costs (including legal fees) and expenses suffered or incurred by the Indemnified Parties or awarded by a court of competent jurisdiction against the Indemnified Parties as a result of or in connection with any claim or action arising out of or in connection with:
- 15.4.1 any breach by the Company its employees, agents, contractors (at any time) of the terms and conditions of this Agreement;
- 15.4.2 any claim that voice, text, data, video, music, audio/video, games, television programmes or any other data, content or information carried by or otherwise disseminated through the Network and Services infringes the Intellectual Property Rights of a third party or any Laws;
- 15.4.3 any claim by any person (including but not limited to Resellers, Customers and End-Users) relating to the sale, provision or supply of the Customer Services save where such claim is caused as a result of H3Gs default under this Agreement;
- 15.4.4 any act, omission, default or negligence of the Resellers or their personnel in connection with the Services or this Agreement;
- 15.4.5 any fraud by the employees, agents, contractors of the Company or Resellers or the Customers or the End-Users; and

15.4.6 any claims relating to the branding of the Company or Reseller or use or resale of USIMs in violation of the relevant terms and conditions of or licence granted by the relevant USIM supplier or Third Party Operators and made available to the Company.

16 **LIABILITY**

16.1 The Company acknowledges that H3G:

16.1.1 does not warrant that H3G will be able to supply the Services at all times nor that the Services will be uninterrupted or error free; and

16.1.2 is not liable to the Company, Resellers, Customers, End-Users or potential Customers for any failure to Activate or Deactivate, or to enable Activation or Deactivation or for any failure to provide part or all of any of the Service, including the failure of any part of the Network or any network failure, congestion or call dropout.

16.2 Neither party excludes or limits liability for:

16.2.1 death or personal injury resulting from the negligence of that party or its directors, officers, employees, contractors or agents;

16.2.2 any breach of undertaking as to title, quiet possession, and freedom from encumbrance implied by law, including any breach of the obligations implied by section 12 Sale of Goods Act 1893 (as amended by the Sale of Goods and Supply of Services Act 1980);

16.2.3 fraud or deceit; or

16.2.4 any other liability which cannot be excluded or limited by Law.

16.3 To the extent permitted by law, H3G excludes all:

16.3.1 tortious liability (including but not limited to liability in negligence); and

16.3.2 conditions and warranties implied by custom, the general law or statute,

arising out of or to the extent to which they relate to any Service, any failure to supply or delay in supplying any Service or breach of any other provision of this Agreement.

16.4 Save as provided in Clauses 16.1 to 16.3 and Clauses 10.9, 15, 19.5, 24.4, the total, collective, aggregate liability of either party in contract, tort (including negligence) or otherwise under or in connection with this Agreement shall be limited to €1 million.

16.5 Save as provided in Clause 16.2, H3G shall not be liable whether in contract, tort, statute or otherwise for any loss of customers, loss of revenue, profits, savings, business opportunity, goodwill or damage to brand and/or reputation whether such losses arise directly or otherwise or any indirect, special or consequential losses or damages howsoever arising.

17 **USE OF THE NETWORK**

17.1 The Company shall use reasonable endeavours to ensure that Customers shall only use the Network with reliable and compatible Broadband Devices that meet all legal requirements for such Broadband Devices.

17.2 To the extent permitted under applicable law, the Company shall procure that Customers agree that the following minimum terms and conditions apply to their use of the Network

17.2.1 the Customer acknowledges that H3G and the Company do not check and are not obligated to monitor the content of information or material available via the Network or the internet and that H3G and The Company are not liable for loss or damage

suffered by the Customer or any other person as a result of using information or material obtained using the Network or the internet, including, but not limited to, loss or damage caused by a virus;

- 17.2.2 the Customer shall not use the Network for any activities which breach any Laws, standards or codes or infringe a third party's rights, or breach any statements, content requirements or codes promulgated by any relevant authority including activities which shall require H3G to take remedial action under any applicable industry code or in a way which interferes with other users or defames, harasses, menaces, restricts or inhabits any other user from using or enjoying the Network or the internet;
 - 17.2.3 the Customer agrees that the possibility of creating or maintaining a connection and the quality of the connection to the Services are not equal or adequate in every location at any time;
 - 17.2.4 the Customer agrees that Services may be adversely affected and may (temporarily) be unavailable as a result of physical factors (such as buildings, tunnels, mountains, etc.), atmospheric circumstances, or adjustments to or maintenance of the Network or another provider of telecommunication services, failure in the interconnection, jamming transmitters or other causes;
 - 17.2.5 the Customer shall protect the Broadband Device against loss, abuse, theft or damage and shall keep the security codes, provided to them, secret and to the extent possible, keep such codes separate and use them sensibly; and
 - 17.2.6 the Customer shall warrant that his or her use of the Broadband Device is restricted to normal use for the purpose of purchasing Customer Services, as intended by such providers according to reasonable standards. The Customer shall be liable for any damage arising as a result of unlawful use of the Services and the Broadband Device. that the following terms and conditions apply to their use of the Network
- 17.3 Customers shall refrain, and prevent others, from using the Broadband Device or Customer Services for any purpose other than that intended by the relevant telecommunications operator, in any way whatsoever, including (i) "annoyance", "spamming" or any other form of harassment, or (ii) committing or inciting third parties to commit, any criminal offence.

18 **DISRUPTION EVENTS**

- 18.1 The Company shall immediately provide written notice to H3G of any event which may result in the material adverse disruption of the Network detailing the nature of such event and the steps being or to be taken to address it and shall promptly notify H3G in writing as soon as the event has subsided at which time H3G shall resume provision of the Services provided the disruption event has been resolved or has subsided to H3G's reasonable satisfaction.
- 18.2 H3G shall be entitled, at any time and without liability or compensation to the Company or any Customer, to temporarily suspend the whole or any part of the Service where such suspension is required for the purposes of a event referred to in Clause 18.1 above or works to modify, expand, reduce, improve, maintain or repair the Network provided that H3G shall where possible:
 - 18.2.1 give the Company reasonable notice of such suspension, explaining the reason therefore; and
 - 18.2.2 use reasonable endeavours to minimise any disruption to the Services and/or to the Network.

19 **ASSISTANCE WITH LAW ENFORCEMENT AGENCIES AND AUTHORITIES**

- 19.1 In the event that an Authority issues a valid warrant or request to the Company in respect of Legal Interception, the Company shall provide H3G with notification of and a proper copy of

such warrant or request as are served on it. H3G shall use reasonable efforts to execute such warrant or request (including warrants or requests served directly on H3G by an Authority) as soon as required under the warrant or request in accordance with the terms of the warrant or request and to the extent that such execution and provisioning is required under Law. Where H3G incurs additional costs in relation to Legal Interception including, but not limited to, costs incurred liaising with law enforcement officials or in preparing for and participating in court proceedings such costs shall be paid by the Company.

- 19.2 In relation to the provision by H3G of any services ancillary to Legal Intercept or the provision by H3G of information to or data retention for an Authority, or other governmental body with appropriate authority to require it, under a valid warrant or lawful request to H3G or the Company in relation to a Customer, the Company agrees to pay H3G applicable Charges.
- 19.3 H3G agrees to provide all reasonably necessary assistance to the Company or the Authority, or other governmental body with appropriate authority to require it, in relation to a lawful request or valid warrant for data retention or information for the duration of the validity of such warrant or request. The Company shall provide H3G with notification of and a proper copy of such warrant or request and H3G shall use reasonable efforts to execute any such warrant or request to H3G or the Company as soon as required under the warrant or request in accordance with the terms of the warrant or request and/or to the extent that such execution and provisioning is required under Law.
- 19.4 The Company acknowledges and agrees that the Network and the capabilities associated with the Network, (including but not limited to interception capabilities) is not fault-free and H3G shall use its best endeavours to comply with any warrant or request, but shall not be liable to the Company in any way if H3G's is unable to assist the Company in full and timely compliance with a warrant or request. To the extent possible, H3G shall at all times use its endeavours to rectify any faults in the Network or its interception capabilities as soon as practicable.
- 19.5 The Company agrees and acknowledges that H3G shall not be liable to any person in respect of any claim arising out of its performance under this Clause 19, save to the extent that such claim arises as a result of any negligent act or omission of breach of contract by H3G, its directors, officers, employees or appointed agents and the Company shall indemnify and hold harmless H3G in this respect.

20 **CONTRACT MANAGEMENT**

- 20.1 Each party shall appoint an account manager who shall act as the main point of contact for the other party in respect of all day to day matters relating to the supply of the Services pursuant to this Agreement ("Account Manager").
- 20.2 The Account Managers shall meet at such intervals as the parties shall determine in order to discuss the progress being made in relation to the provision of the Services.
- 20.3 Each party must make their Account Manager available to meet monthly (or as otherwise agreed) with the other party for the purposes of overseeing this Agreement and reviewing the relationship between H3G and the Company. At those review meetings the parties will share with each other information relevant to the provision of the Services and other obligations under this Agreement that is likely to enhance their business relationship including, without limitation, H3G's network development plans, network coverage information, product roadmaps and service issues and each party will treat information in relation to the business of the other party as Confidential Information of the other party.
- 20.4 On request by H3G from time to time, the Company must provide to H3G, and where necessary procure that the Resellers provide to H3G information relating to the Company, Resellers or the Customer Service as required by H3G:

20.4.1 to enable H3G to help reduce the incidence of fraud;

- 20.4.2 to assist H3G in complying with its regulatory obligations and its obligations to report on compliance with those obligations; and
- 20.5 On request by the Company from time to time, but subject to H3G's obligations of confidentiality to third parties and /or pursuant to applicable Laws, H3G shall provide to the Company information relating to the Network or Customers reasonably required by the Company:
 - 20.5.1 to enable the Company to monitor and help reduce the incidence of fraud of the Customers;
 - 20.5.2 to assess whether or not the Company or Reseller has complied, is complying and will be able to continue to comply with all obligations imposed on the Company and/or Resellers under this Agreement; and
 - 20.5.3 to assist the Company in complying with its regulatory obligations and its obligations to report on compliance with those obligations.

21 **SUB-CONTRACTORS**

The Company may not subcontract the performance of its obligations (including its obligations to connect to the Interface and carry out the Business Procedures set out in Schedule 5) under this Agreement without first obtaining the prior written consent of H3G, such consent not to be unreasonably withheld. The Company shall at all times remain wholly responsible to H3G for all its obligations under this Agreement and no consent given by H3G to the appointment of any sub-contractor shall relieve H3G from its obligations under this Agreement.

22 **STAFF**

- 22.1 Neither party shall, during the period beginning on the Commencement Date and ending on the date which is 6 months after the expiration or termination of this Agreement, directly or indirectly solicit or entice away or endeavour to solicit or entice away from the other party any employee of the other party who has been engaged in the provision of Services or the performance of this Agreement.
- 22.2 Clause 22.1 shall not prevent either party (or any group undertaking of either party) from soliciting the services of, offering to employ or actually employing any person who, without any separate solicitation by that party or any of its group undertakings, responds to a genuine advertisement by that party or any of its group undertakings which is made generally available and not directed at employees of the other party or its group undertakings.
- 22.3 Each party will ensure that its Staff are made aware of the confidential nature of the other Party's Confidential Information and that they are reminded of their duties of confidentiality. At H3G's request the Company will ensure that before each member of the Company's Staff commences performance of any Services, he or she has agreed to confidentiality obligations in a form which reflect the confidentiality obligations as set out in this Agreement.

23 **CONFIDENTIALITY**

- 23.1 Each party in receipt of Confidential Information (the "Receiving Party") shall:
 - 23.1.1 keep the Confidential Information confidential;
 - 23.1.2 keep the Confidential Information secure and protected against theft, damage, loss or unauthorised access;
 - 23.1.3 not disclose the Confidential Information to any person, other than in accordance with Clause 23.3 and Clause 23.5 unless it first obtains the other party's written consent (the "Disclosing Party"); and

- 23.1.4 not use the Confidential Information other than:
- (a) in the case of H3G for the performance of its obligations under this Agreement; or
 - (b) in the case of the Company, the receipt and use of the Services.
- 23.2 The Company acknowledges that, whether by virtue of and in the course of this Agreement or otherwise, it shall receive or otherwise become aware of Confidential Information belonging to H3G and H3G Affiliates.
- 23.3 The Receiving Party undertakes to disclose Confidential Information only to those of its officers, employees, agents and contractors to whom, and to the extent to which, such disclosure is necessary for the purposes contemplated under this Agreement, and to procure that such officers, employees, agents and contractors and sub-contractors execute and observe the terms of a confidentiality undertaking no less onerous than the confidentiality provisions in this Agreement.
- 23.4 Upon a written request from the Disclosing Party, the Receiving Party shall return any and all Confidential Information of the Disclosing Party then in its possession or control (including expunging from any word processor or similar device) and will not retain any copies of the same. The Receiving Party shall procure that its sub-contractors also comply with the provisions of this Clause 23.4
- 23.5 The terms of and obligations imposed by this Clause 23 shall survive the variation, renewal or termination of this Agreement but shall not apply to any Confidential Information which:
- 23.5.1 at the time of receipt by the Disclosing Party is in the public domain, or subsequently comes into the public domain through no fault of the Disclosing Party, its officers, employees, agents or contractors;
 - 23.5.2 is lawfully received by the Receiving Party from a third party on an unrestricted basis;
 - 23.5.3 is already known to the Receiving Party before receipt hereunder;
 - 23.5.4 is independently developed by the Receiving Party or its employees, agents or contractors; or
 - 23.5.5 is required by the rules of any stock exchange applicable to H3G, the Company, any H3G Affiliates or Company Affiliates, or any law, regulation or order of a competent authority to be disclosed by the Receiving Party, or to a professional adviser of the Receiving Party, provided the Disclosing Party is given reasonable advance notice of the intended disclosure and a reasonable opportunity to challenge the same and, in the case of disclosure to a professional adviser, provided that such professional adviser undertakes in writing to be bound by obligations of confidentiality of at least as high a standard as those imposed on the Receiving Party under this Clause 23.

24 DATA PROTECTION

- 24.1 The Company shall comply with the Data Protection Act 1988 and 2003, and the European Communities (Electronic Communications Networks and Services) (Data Protection and Privacy) Regulations 2003 (SI No 535 of 2003) (as applicable and any amendments thereof) (the "Data Protection Legislation") and any regulations made under or separate to the Data Protection Legislation or any other legislation relating to the protection of personal data and privacy in electronic communications.
- 24.2 The Parties acknowledge and agree that, for the purposes of the Data Protection Legislation the Company is the "data controller" of personal data in respect of Customers, and H3G is the "data processor" in respect of such data.

- 24.3 The Company will provide to H3G the names and addresses of each Customer that has signed up to Services no later than 1 month after each Customer has entered into a Customer Contract. When requested by H3G (acting reasonably) and only where necessary to confirm the compliance by the Company of its obligations under or in connection with this Agreement the Company will also provide proof of an address to H3G for each Customer to ensure customer is resident in the National Broadband Scheme Coverage Areas. The form of Customer proof of address is set out in Schedule 4. It is a condition of this Agreement that the Company must ensure that the terms and conditions of each Customer Contract include a provision which obligates the Customer to provide H3G with proof of address of that Customer and entitles the Company and H3G to contact the Customer as a means of verification and that such Customer personal data must be disclosed to H3G and other third parties in relation to the provision of the Services. The Company shall ensure that any processing of Customer Data is undertaken in accordance with Data Protection Legislation.
- 24.4 The Company agrees to defend, indemnify, keep indemnified and hold H3G, its directors, officers, employees and agents harmless against all costs, losses, claims, damages, expenses or proceedings which H3G may incur or suffer arising out of any breach of the warranties and undertakings in this Agreement including in particular this Clause 24.

25 **INSURANCE**

- 25.1 Without prejudice to the generality of the foregoing, the Company shall take out and maintain in force insurance policies to the value sufficient to meet its liabilities under or in connection with this Contract including but not limited to employer's liability, public (including products) liability and professional indemnity insurance. Upon H3G's request the Company will provide H3G with evidence that such insurance is in full force and effect.
- 25.2 Such policy or policies referred to in Clause 25.1 shall be with insurers, shall have face amounts, levels of excess and other terms reasonably acceptable to H3G. If the Company fails to effect and keep in force the aforementioned insurance policies or to promptly provide copies of such insurance policies or premium receipts to H3G, then H3G may effect and keep in force any such insurance and pay such premiums as may be necessary for that purpose and recover such sums from the Company whether by way of deduction or otherwise.

26 **COMPLIANCE WITH LAWS**

- 26.1 The Company shall ensure that it and each of its employees, contractors, agents, authorised subcontractor shall comply with the obligations provided for under this Agreement if such agent, contractor or authorised sub-contractor were the Company for the purposes of this Agreement and shall comply with all applicable Laws including and guidance, codes, directions issued by any Regulators, that are from time to time applicable to the performance of such obligations and the resale of Services, and shall ensure that in the performance of its obligations and the exercise of its rights to resell the Services in accordance with this Agreement will not place H3G in breach of any then current Laws or approvals to which H3G is subject, including those issued by any Regulator.

27 **FORCE MAJEURE**

- 27.1 If a party (the "Affected Party") is prevented from performing any of its material obligations (in whole or in part) under this Agreement by reason of a Force Majeure Event, it must immediately notify the other party (the "Unaffected Party") in writing of the Force Majeure Event and keep the Unaffected Party regularly informed of the progress in resolving the Force Majeure Event.
- 27.2 The Affected Party must take all reasonable steps to minimise the adverse effects of the Force Majeure Event on the performance of its obligations under this Agreement.
- 27.3 Subject to Clause 27.4 neither the Affected Party nor the Unaffected Party will be treated as being in breach of this Agreement (but only to the extent it is prevented from performing any of its obligations by reason of the Affected Party's failure to perform as a result of the Force

Majeure Event), or otherwise liable to the other, by reason of any delay in performance, or non-performance of any of its obligations due to a Force Majeure Event provided that no delay or failure by a sub-contractor or supplier of Reseller will relieve Reseller from liability for any such delay or failure except where that delay or failure would have constituted a Force Majeure Event if the sub-contractor or supplier concerned had been a party to this Agreement.

- 27.4 If the Affected Party fails to comply with its obligations under Clauses 27.1 and 27.2 above then no relief for a Force Majeure Event, including the provisions of Clause 27.3 will be available to it and the obligations of each party will continue in full force and effect.
- 27.5 If the event of Force Majeure continues for longer than fourteen (14) days then the Unaffected Party may at the expiry of such fourteen (14) days period, provided the event of Force Majeure is still subsisting, give notice in writing to the Affected Party terminating this Agreement with immediate effect.

28 NOTICES

- 28.1 Any notice, consent, invoice or other communication to be given under this Agreement must be in writing and delivered by hand or courier, or sent by registered post (if it is an address in the Ireland) or by air mail (if to an address not in the Ireland) or by facsimile to the address of the recipient set out below (or as otherwise notified from time to time under this Agreement):

H3G:

Address: Hutchison 3G Ireland Limited
3rd Floor
6-10 Suffolk Street
Dublin 2

Attention of: **Senior Counsel**

Facsimile: +xxxxxxxxxxxxx

Company: [•]

Address: [•]

Attention of: [•]

Facsimile: [•]

- 28.2 For the purposes of this Clause 28.2 "Notice Day" will mean any day (other than a Saturday or Sunday) on which the banks are ordinarily open for business in the city of Dublin. This Clause 28.2 will apply in the absence of proof of earlier receipt. A notice, demand or other communication:

28.2.1 served by registered post will be deemed duly served on an addressee in the Ireland two (2) Notice Days after posting; and

28.2.2 served by mail will be deemed duly served on an addressee five (5) Notice Days after posting; and

28.2.3 delivered by facsimile will be deemed duly served on an addressee at the time of transmission (or at 9.00 the following Notice Day if transmitted after 18.00) provided that a valid transmission receipt is generated by the addressee's facsimile machine and received by the sender.

29 **ASSIGNMENT**

- 29.1 The Company may not assign, transfer, novate or otherwise dispose of to any third party any right or obligation under this Agreement without H3G's prior written consent.
- 29.2 The Company agrees and undertakes to H3G that it shall not and that it shall procure that the Resellers shall not sell, assign, transfer or otherwise dispose of, whether in whole or in part, its interest in the Customer Contracts, during the Initial Term.

30 **DISPUTES**

- 30.1 All disputes between the parties arising out of or relating to this Agreement shall be referred to the parties' respective Account Managers for resolution. If, having been so referred, the dispute is not resolved within a maximum of ten (10) Business Days, such dispute may be referred to the first level, being H3G's project sponsor and the Company account director.
- 30.2 If the dispute is not resolved within a maximum of ten (10) Business Days of being referred to the first level, such dispute may be referred to the second level being H3G's Head of National Broadband Scheme and the Company managing director.
- 30.3 If the dispute cannot be resolved within a maximum of ten (10) Business Days of being referred to the second level, either party may take whatever action is available to it at law or under this Agreement. Nothing in this Clause 30.3 shall prevent either party from seeking immediate preventative relief such as an injunction.

31 **COSTS**

Except as otherwise expressly provided in this Agreement or otherwise agreed in writing between the parties, each party shall be responsible for its own costs incurred in preparing and performing its obligations under this Agreement.

32 **NO WAIVER**

The failure of either party to enforce or to exercise at any time or for any period of time any term of or any right pursuant to this Agreement does not constitute, and shall not be construed as, a waiver of such term or right and shall in no way affect that party's right later to enforce or to exercise it.

33 **SEVERABILITY**

If any term of this Agreement is found to be illegal, invalid or unenforceable under any applicable law, such term shall, insofar as it is severable from the remaining terms, be deemed omitted from this Agreement and shall in no way affect the legality, validity or enforceability of the remaining terms.

34 **ENTIRE AGREEMENT**

Subject to Clause 38 this Agreement contains all the terms agreed between the parties regarding its subject matter and supersedes any prior agreement, understanding or arrangement between the parties, whether oral or in writing. No representation, undertaking or promise shall be taken to have been given or be implied from anything said or written in negotiations between the parties prior to this Agreement except as expressly stated in this Agreement. Neither party shall have any remedy in respect of any untrue statement made by the other upon which that party relied in entering into this Agreement (unless such untrue statement was made fraudulently or relates to a fundamental matter including a matter fundamental to a party's ability to perform its obligation under this Agreement) and that party's only remedies shall be for breach of contract as provided in this Agreement.

35 **SURVIVAL**

Provisions of this Agreement which either are expressed to survive its expiry or termination or from their nature or context it is contemplated that they are to survive such termination, shall remain in full force and effect notwithstanding such expiry or termination.

36 **RELATIONSHIP OF THE PARTIES**

The relationship of the parties is that of independent contractors dealing at arm’s length. Except as otherwise stated in this Agreement, nothing in this Agreement shall constitute the parties as partners, joint ventures or co-owners, or constitute either party as the agent, employee or representative of the other, or empower either party to act for, bind or otherwise create or assume any obligation on behalf of the other, and neither party shall hold itself out as having authority to do the same.

37 **FURTHER ASSURANCES**

The parties shall do and execute all such further acts and things as are reasonably required to give full effect to the rights given and the transactions contemplated by this Agreement.

38 **VARIATION**

Save as expressly provided for under this Agreement, no alteration to or variation of this Agreement shall take effect unless and until the same is agreed by both parties in writing. The Company acknowledges and agrees that all changes to this Agreement must be approved in advance with the DCENR. Any change to the Services pursuant to Clause 4, or change to the Interface or BDR format pursuant to Clauses 4.9 shall be documented in writing by H3G as soon as possible following such change.

39 **GOVERNING LAW AND JURISDICTION**

39.1 The construction, validity and performance of this Agreement shall be governed by Irish law and the parties submit to the exclusive jurisdiction of the Irish Courts.

39.2 The parties acknowledge and agree that a breach by the Company of any of the terms of this Agreement may result in irreparable and continuing damage to H3G for which there may or will be no adequate remedy at law, and that in the event of such breach, H3G shall be entitled to apply for injunctive relief and/or a decree for specific performance and such other and further relief as may be appropriate.

40 **COUNTERPARTS**

This Agreement may be executed in several counterparts, each of which shall be deemed an original, but all of which together shall constitute one and the same document.

IN WITNESS whereof, the parties hereto have executed this Agreement as of the date first above written.

Signed by) Name:
a duly authorised) Date:
representative on behalf of) Signature:
Hutchison 3G Ireland Limited)

Signed by) Name:
a duly authorised) Date:
representative on behalf of) Signature:

Hutchison 3G Ireland Limited)

Signed by
a duly authorised
representative on behalf of
Company)

) Name:
) Date:
) Signature:

SCHEDULE 1

SERVICES AND USAGE PROFILE

SERVICES

Core Services: Broadband service as per specification below

	Wholesale Service	Target
1	Minimum Download speed – Minimum speed in Mbps that files are downloaded by a Subscriber from the Internet at the H3GI ISP. Note: Download speeds of up to 5 Mbps are possible.	1.2Mbps
2	Maximum Contention Ratio – Maximum number of Subscribers that may be sharing the Minimum specification Retail Service at any one time.	36:1
3	Minimum Upload speed – speed in which files are uploaded by a Subscriber to the Internet at the Tenderers ISP. Note: Upload speeds of up to 1.8 Mbps are possible.	200Kbps
4	Always On	Yes
5	Minimum Data Cap (Uncharged)	15GB - Data Cap (Uncharged)
6	Latency – The maximum round trip delay of a packet (ms) from the Subscriber to the Internet and back	~120ms

SCHEDULE 2

CHARGES

Tariff Type	Tariff
Wholesale Tariff per active sim per month	€11.08 (Ex VAT)
Wholesale One-Off Charges¹	€23.97 (Ex VAT)
Wholesale Services Ancillary Charges	2.77cent (Ex VAT) per MB used outside of inclusive data bundle

The Service and Tariff Charges are as per the Wholesale Access Offer Overview and may be subject to change from time to time.

¹ This charge includes the provision of subscriber CPE

SCHEDULE 3

COMPULSORY CUSTOMER TERMS

As per Wholesale End User Terms and Conditions

SCHEDULE 4
CUSTOMER PROOF REQUIREMENTS

Part A: Acceptable Proofs for sales via Online and Telesales channels

Option 1

Proof of Delivery Address

Proof of Address as per Table 1 and Table 2 for consumer and business proofs

OR

Option 2

Proof of Delivery Address

Have implemented a system where address details of visa/laser cards are checked against relevant bank details. Authorised Undertakings provide in writing that this system for checking on-line and telesales is in place.

OR

Option 3

Other acceptable proofs of Delivery address and Address as may be agreed between H3GI and Authorised Undertakings

Part B: Acceptable Proofs for sales via Direct Sales Channels (i.e. customer purchases in the presence of a sales person)

Outlined below in Tables 1 and 2 are the proof requirements for sales via Direct sales channels.

<p>TABLE 1: REQUIRED CONSUMER PROOFS FROM THE COMPANY REF: NATIONAL BROADBAND SCHEME</p> <p>PROOF OF IDENTITY / PROOF OF ADDRESS POLICY FOR NATIONAL BROADBAND SCHEME CUSTOMERS</p> <p>EFFECTIVE FROM 23rd December 2008</p>		
<p>ONE PROOF OF IDENTITY AND ONE PROOF OF ADDRESS FROM THE LISTS BELOW MUST BE TAKEN FOR ALL NEW NATIONAL BROADBAND SCHEME CUSTOMERS.</p>		
ACCEPTABLE PROOFS OF IDENTITY	PROOF REQUIREMENTS	UNACCEPTABLE PROOFS OF IDENTITY
<ul style="list-style-type: none"> • Full European Photo Driving Licence or • Provisional European Photo Driving Licence 	<ul style="list-style-type: none"> • Licence issued by one of the 27 EU member states only • Photograph of Customer • Customer's Full Name • Full Postal Address • Valid from and to dates and not expired • Signature included • Must show driver number • Date of Birth – <u>check it matches the registration details</u> 	<ul style="list-style-type: none"> • Expired Licences • Handwritten Licences • Those not Sealed or Laminated • Any item not specifically listed as acceptable

<ul style="list-style-type: none"> • Passport 	<ul style="list-style-type: none"> • Photograph of Customer • Customer's Full Name • Valid and not expired • Printed in Roman characters • Date of Birth 	<ul style="list-style-type: none"> • Expired passports • Handwritten passports • Any item not specifically listed as acceptable
ACCEPTABLE PROOFS OF ADDRESS	PROOF REQUIREMENTS	UNACCEPTABLE PROOFS OF ADDRESS
<ul style="list-style-type: none"> • Bank / Building Society / Credit Card Statement 	<ul style="list-style-type: none"> • Customer's name (Initials & Surname) • Full Postal Address • Account Name and Number • Dated no later than 3 months before connection date • Name of issuer 	<ul style="list-style-type: none"> • Letters of any type (excluding P60) • Utility statements that show 'This is not a bill' • E-mailed or electronic statements, letters or documents • Promotional mail shots (e.g. offering Personal Loans or Credit Cards) • Statements / Licences / Bills / Books in the name of a Third Party • Bank / Building Society Account Books • Gardai or Military Identity cards (Disciplinary offence to allow copies to be taken) • Any item not specifically listed as acceptable
<ul style="list-style-type: none"> • Utility Bill (Water, Gas, Electricity, Fixed Line Telephone) • Mobile Network Operator Bill • P60 Letter • Motor Insurance Certificate • Income Tax Certificate 	<ul style="list-style-type: none"> • Customer's Name (Initials & Surname) • Full Postal Address • Supply Address and Postal Address must be the same • No more than 3 months old • Customer / Account reference number • Mobile Bills – Requirements as above, plus the account must be up to date 	
<ul style="list-style-type: none"> • Family Allowance / Pension Book 	<ul style="list-style-type: none"> • Customer's Full Name • Full Postal Address • Date of issue stamp / date of last order 	

- **All proofs must be legible and clear photocopies of original documents taken by a member of Authorised Undertakings staff or resellers at point of sale or at the time of registration.**
- **A method must be in place in store to associate customers proofs with the IMEI and MSISDN. The proofs should be retained for at least five years from the date of connection. Copies of proofs sent to 3 must be marked with the 3 MSISDN and IMEI number.**
- **Fraud is defined as:**
 - **False Identity Fraud - Use of a false name with an address**
 - **Impersonation Fraud - Use, by another person, of a name and/or address**
 - **Application Fraud - An application/proposal for any facility with one or more material falsehoods in the information provided**
 - **Conversion Fraud - Conversion (disposal or sale) of goods (to which the hirer/buyer does not have title) under a hire-purchase, conditional sale, contract hire, leasing or rental agreement**
 - **First Party Fraud - Opening an account or other facility for a fraudulent purpose, or the fraudulent misuse of an account or facility.**
 - **Aiding & Abetting - Aiding, abetting or assisting, or conspiring with, another or others to fraudulently procure credit, hire or other facilities, or other product or service**
- **You can store the proof copies electronically if you choose to, as long as you can provide a printed paper copy and the image quality of this copy is legible and clear.**
- **All proofs must be printed rather than hand written.**
- **Faxed proofs are not acceptable.**
- **All proofs must pre-date connection.**
- **If using computer equipment to store information relating to an application, you must ensure that access is restricted to staff with a legitimate need. This will help you meet your obligations under the Data Protection Act (DPA) to avoid the possible misuse of sensitive Customer information.**
- **It is your responsibility to ensure that the storage and carriage of proofs is secure and DPA compliant.**

If you have any queries about this policy please contact your Account Manager in the first instance.

TABLE 2: NATIONAL BROADBAND SCHEME BUSINESS SALES – LIMITED COMPANY, CHARITY AND PUBLIC SECTOR.

BUSINESS PROOF POLICY FOR BUSINESS CONNECTIONS

EFFECTIVE FROM 23rd December 2008

SUMMARY

1 PROOF MUST BE TAKEN FROM LIST 1, BUSINESS PROOFS.

IF APPLICABLE, 1 PROOF MUST BE TAKEN FROM LIST 2, ALTERNATIVE BUSINESS ADDRESS(ES).

LIST 1 – BUSINESS PROOFS

**ACCEPTABLE
BUSINESS PROOFS**

PROOF REQUIREMENTS

**UNACCEPTABLE
PROOFS**

<ul style="list-style-type: none"> ▪ Purchase Order 	<ul style="list-style-type: none"> ▪ Must have a Purchase Order number. ▪ Must be addressed to the Authorised Undertaking or its reseller. ▪ Must clearly detail the products and services being requested i.e. number of CPE, tariffs etc. ▪ Must include a fixed telephone number ▪ Must be signed by company's Accounts Payable Department or Director. ▪ Ltd Co only - Must have the Registered Company Name, Registration Number and registered office address (and Trading Name and Trading address if different). ▪ Charity only - Must have the Charity Registration Number and registered address. 	<ul style="list-style-type: none"> ▪ Anything other than stated.
---	---	--

<ul style="list-style-type: none"> ▪ Official Company Request 	<ul style="list-style-type: none"> ▪ Must be on company letter headed paper. ▪ Must be addressed to the Authorised Undertaking or its reseller. ▪ Must clearly detail the products and services being requested i.e. CPE, tariffs etc. ▪ Must include a fixed telephone number ▪ Must be signed by company's Accounts Payable Department or Director. ▪ Ltd Co only - Must have the Registered Company Name, Registration Number and registered office address (and Trading Name and Trading address if different). ▪ Charity only - Must have the Charity Registration Number and registered address. 	
<p>NOTE: IF AN ALTERNATIVE BILLING / TRADING ADDRESS IS TO BE CAPTURED DURING THE APPLICATION, ASSOCIATED PROOFS ARE REQUIRED – ONE PROOF FROM THE LIST 2 MUST BE PROVIDED. IF PROOF CAN NOT BE PROVIDED, THE ONLY ADDRESS TO BE CAPTURED IS THE ONE PROVIDED BY LIST 1.</p>		
<p>LIST 2 – ALTERNATIVE BUSINESS ADDRESS PROOFS</p>		

ACCEPTABLE BUSINESS PROOFS FOR ALTERNATIVE BILLING (AND / OR TRADING) ADDRESS	PROOF REQUIREMENTS	UNACCEPTABLE PROOFS
<ul style="list-style-type: none"> ▪ Utility Bill (Water, Gas, Electricity, Fixed Line Telephone) ▪ Mobile Network Operator Bill 	<ul style="list-style-type: none"> ▪ Business Name matching purchase order or official company request ▪ Full Postal Address ▪ No more than 3 months old ▪ Customer / Account reference number ▪ Mobile Bills – Requirements as above, plus the account must be up to date 	<ul style="list-style-type: none"> ▪ Anything other than stated.
<ul style="list-style-type: none"> ▪ Bank / Building Society / Credit Card Statement 	<ul style="list-style-type: none"> ▪ Business Name matching purchase order or official company request ▪ Full Postal Address ▪ Account Name and Number ▪ Dated no later than 3 months before connection date ▪ Name of issuer 	

- All proofs must be legible and clear photocopies of original documents taken by a member of staff prior to the point of sale at the time of registration.
- A method must be in place in store to associate customers proofs with the IMEI(s) and MSISDN(s). The proofs should be retained for at least five years from the date of connection. Copies of proofs sent to 3 must be marked with the 3 MSISDN and IMEI number(s).
- Fraud is defined as:
 - False Identity Fraud - Use of a false name with an address.
 - Impersonation Fraud - Use, by another person, of a name and/or address.
 - Application Fraud - An application/proposal for any facility with one or more material falsehoods in the information provided.
 - Conversion Fraud - Conversion (disposal or sale) of goods (to which the hirer/buyer does not have title) under a hire-purchase, conditional sale, contract hire, leasing or rental agreement.
 - First Party Fraud - Opening an account or other facility for a fraudulent purpose, or the fraudulent misuse of an account or facility.
 - Aiding & Abetting - Aiding, abetting or assisting, or conspiring with, another or others to fraudulently procure credit, hire or other facilities, or other product or service.
- You can store the proof copies electronically if you choose to, as long as you provide a printed paper copy and the image quality of this copy is legible and clear.
- All proofs must be printed rather than hand written.
- Faxed proofs are not acceptable.
- All proofs must pre-date connection.
- If using computer equipment to store information relating to an application, you must ensure that access is restricted to staff with a legitimate need. This will help you meet your obligations under the Data Protection Act to avoid the possible misuse of sensitive Customer information.
- It is your responsibility to ensure that the storage and carriage of proofs is secure and DPA compliant.

If you have any queries about this policy please contact your Account Manager in the first instance.

CUSTOMER PROOF REQUIREMENTS

SCHEDULE 5

WHOLESALE END USER END TO END PROCESS DEFINITION

Project Definition

Purpose of this document

The purpose of this document is to outline a generic process map which can be used to represent any prospective Wholesale End User coming onto 3's network and the processes that must be in place prior to launch.

Background

The complete E2E Wholesale End User setup process can be used in part or whole for any prospective customers to prove to 3 that they are ready to launch their service successfully.

Scope

The scope of this document is an End to End Process Map detailing all the processes that a prospective Wholesale End User must successfully set up on 3's network before their launch. The Wholesale End User is referred to as a Service provider (SP) in this document.

In scope

1. E2E-001 SP Setup Process
2. E2E-002 Activate an SP Customer
3. E2E-003 Post Sale Support of a SP Customer
4. E2E-004 Provide CDRs to Service Provider
5. E2E-005 Invoice a Service Provider
6. E2E-006 Lost or Stolen Process When SP Connect is Down
7. E2E-007 Disconnect a SP Customer
8. E2E-008 Monitor Traffic for Suspect Activity Process
9. E2E-009 SP Connect Availability
10. E2E-010 Respond to Invoice or CDR Queries
11. E2E-011 Query Transaction Status
12. E2E-012 SP to 3 Fault Handling
13. E2E-013 Supply Chain Logistics Ordering

14. E2E-014 SCL Returns and Faults
15. E2E-015 Update Finance Details
16. E2E-017 Customer Calls 3 Instead of MVNO in Error

64.

Business Process Context Diagram

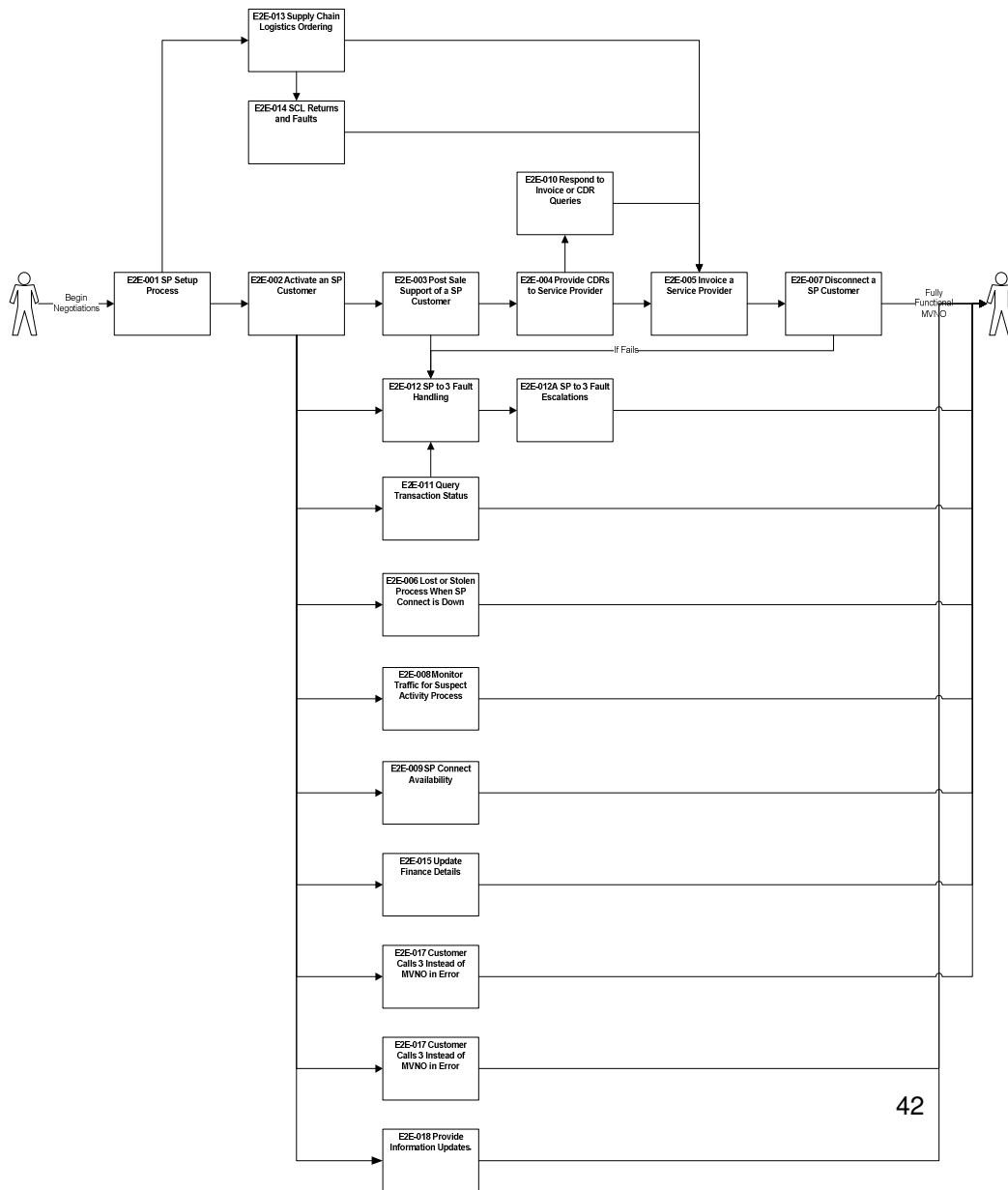

Legend

E2E-001 SP Setup Process

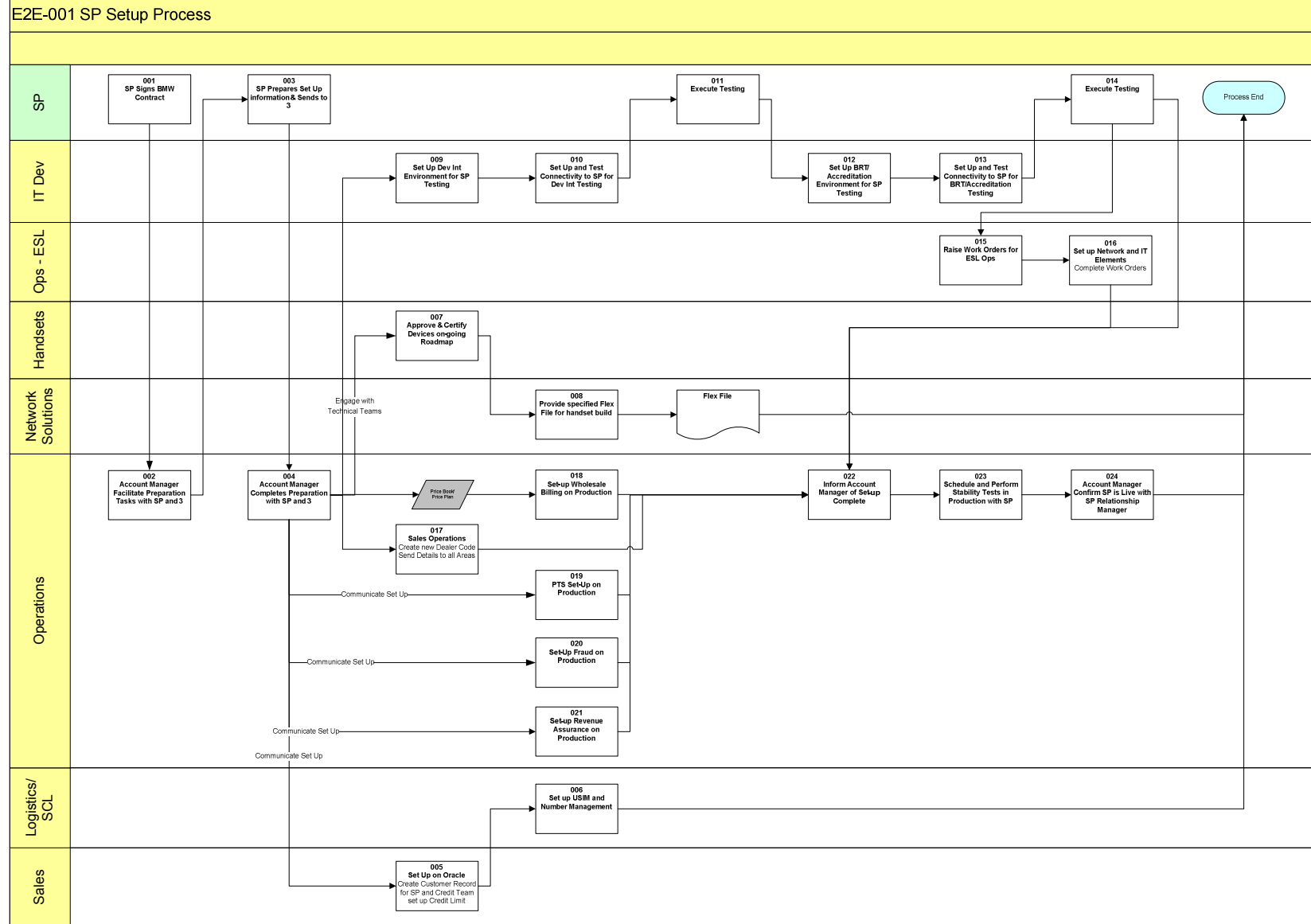

Process Name	E2E-001 SP Setup Process	Process Owner	Peter Adams (NBS Project Manager),
Step Id	Description		
001	SP Signs Wholesale Contract 3 and SP To Sign Contract		
002	Account Manager Facilitate Preparation Tasks with SP and 3 Facilitate gathering of Information Requirements from SP		
003	SP Prepares Set-Up Information and Sends to 3 1. SP receives Set-Up Information Requirements from Account Manager 2. SP Completes Set-Up Information Requirements with help from Account Manager		
004	Account Manager Completes Preparation with SP and 3 1. Check Set-Up Information Requirements for Completeness 2. Pass Correct Information to Fraud, Network, Billing, Mediation, Sales Operations, SCL		
005	Set Up on Oracle 1. Receive Set-Up information from Account Manager/Sales Operations 2. Create Customer Record on Oracle 3. Upon completion new account application approval process, send email to Pre-Sales Support requesting account set up and provide copy of application form and account code details 4. Receive email requesting account set up and copy of application. Print email request and attach to copy of application 5. Set-up in Oracle A/R 6. Set-up Oracle Order Management 7. Send Email to Commercial Credit and Sales Operation with Oracle Customer Number confirming account set up is complete. File email request and application form in Customer Set Up Request Folder 8. Engage with SP Logistics Team. Ensure Communications Link is in Place. 9. Credit Team Set Up Credit Limit 10. SCL configure Oracle Sales Order Management		
006	Set Up USIM and Number Management 1. Receive Dealer Code from Sale Ops 2. Receive Number Block from Account Manager and SP. 3. Determine SP SIM Profile 4. Physical Branding Issues Resolved		
007	Approve and Certify Devices on-going roadmap 1. Receive Devices from Account Manager 2. Certify Devices		

008	Provide specified Flex File for handset build 1. Require Generic MVNO/SP Build 2. Approve and Build Flex File
009	Set Up Dev Int Env for SP Testing Dev Int testing is optional but advised
010	Set Up and Test Connectivity with SP for Dev Int Testing 1. SP to provide Connectivity Test Person. Require Name, Contact Details, and Address. 2. SP receives software application via email for connectivity tests, together with login details for VPN and BMW Modules from ESL 3. SP and 3 use BRT document as a template for connectivity tests 4. Work Order raised with ESL to set-up SP 5. Connectivity test Schedule agreed with daily/weekly calls to resolve issues and monitor progress 6. SP performs Connectivity Tests Dev Int testing is optional but advised
011	Execute Testing For Dev Int. Dev Int testing is optional but advised.
012	Set Up BRT/Accreditation Environment for SP Testing
013	Set Up and Test Connectivity with SP for BRT/Accreditation Testing 1. SP to provide Connectivity Test Person. Require Name, Contact Details, and Address. 2. SP receives software application via email for connectivity tests, together with login details for VPN and BMW Modules from ESL 3. SP and 3 use BRT document as a template for connectivity tests 4. Work Order raised with ESL to set-up SP 5. Connectivity test Schedule agreed with daily/weekly calls to resolve issues and monitor progress 6. SP performs Connectivity Tests
014	Execute Testing For BRT/Accreditation Testing
015	Raise Work Orders for ESL Ops CTO Engage with ESL and raise Work Orders
016	Set up Network and IT Elements (Complete work orders) 1. Complete Work Orders for SP Connect, Intelligent Network, NumerIQ, BMI, CCC, Provident, IntermediatE, Interconnect, Oracle and PeopleSoft 2. ESL Tests
017	Sales Operations. 1. Create New Dealer Code for SP

	2. Pass New Dealer Code to Fraud, Network, Billing, Mediation, Sales Operations, SCL
018	<p>Set-Up Wholesale Billing on Production</p> <ol style="list-style-type: none"> 1. Manual Process to receive SP Billing Details on Billing Template 2. Receive and Check SP Billing Details 3. Set-up Interconnect Billing with SP required attributes. Reserve a Billing Account Number for SP. Billing dependent on ESL Network Operations tasks. 4. Configure calendars 5. Configure day, evening, weekend breakdown 6. Configure tiers and CNP 7. Configure Rates 8. Configure Products
019	<p>PTS Set-Up on Production</p> <ol style="list-style-type: none"> 1. Engage resource planning 2. Engage all Contact Centre departments 3. Conduct Impact Analysis to Contact Centre 4. Understand subscriber number increase and whether this can be supported 5. Set-up Luccid and Service Checker, and Fault Diagnostic Documentation 6. Test handover of faults from SP to 3. Template is complete. Ensure all Scenarios are to be covered. 7. Test Comms process between for Major Outages. 8. Set-up Major Outage SMS for Account Manager of MVNO/SP.
020	<p>Set Up Fraud on Production</p> <ol style="list-style-type: none"> 1. Receive CFS details of SP 2. Set Up SP Contact Details into System in order to allow dummy SDRs 3. Receive Fraud Rules from SP 4. Set-up Fraud rules (Escalation and Resolution based on Service Agreement) 5. Set-up Comms with SP Fraud 6. Test SP Fraud Rules and Service Level 7. Test Comms between 3 Fraud and SP Fraud 8. Test Thresholds 9. Agree Artificial Inflation of Traffic thresholds and policy
021	<p>Setup Revenue Assurance on Production</p> <ol style="list-style-type: none"> 1. Raise CR for Reconciliation for new MVNO/SP 2. CDR delivery to SP (setup, on-going and feedback) 3. On-going receipt of CDRs 4. On-going reconciliation of CDRs (accuracy and completeness of CDRs to support all other processes) 5. Invoice queries 6. Root cause analysis of invoice queries

	<ul style="list-style-type: none"> 7. Query resolution (CDRs, wholesale invoice rates) 8. Visibility of usage profiles 9. Suspense and filtered records 10. Highlight possible future impact of OFCOM Metering and Billing accreditation
022	<p>Inform Account Manager of Set-up Complete</p> <ul style="list-style-type: none"> 1. Network Elements set-up complete, move to live 2. Fraud Set-up complete, move to live 3. Billing Set-up complete, move to live 4. Revenue Assurance Set-up complete, move to live 5. SCL Set-up complete 6. Sales Operations Set-up complete 7. Account Manager is informed that SP is set-up and live
023	Schedule and Perform Stability Tests in Production with SP
024	<p>Account Manager Confirm SP is Live with SP Relationship Manager</p> <ul style="list-style-type: none"> 1. Receive confirmation from Network Ops, Billing and SCL 2. Check that Testing is complete and signed off 3. Inform SP that service is live and ready.

These are one-off tasks when engaging with a new SP as opposed to regular on-going business and usual tasks.

E2E-002 Activate an SP Customer

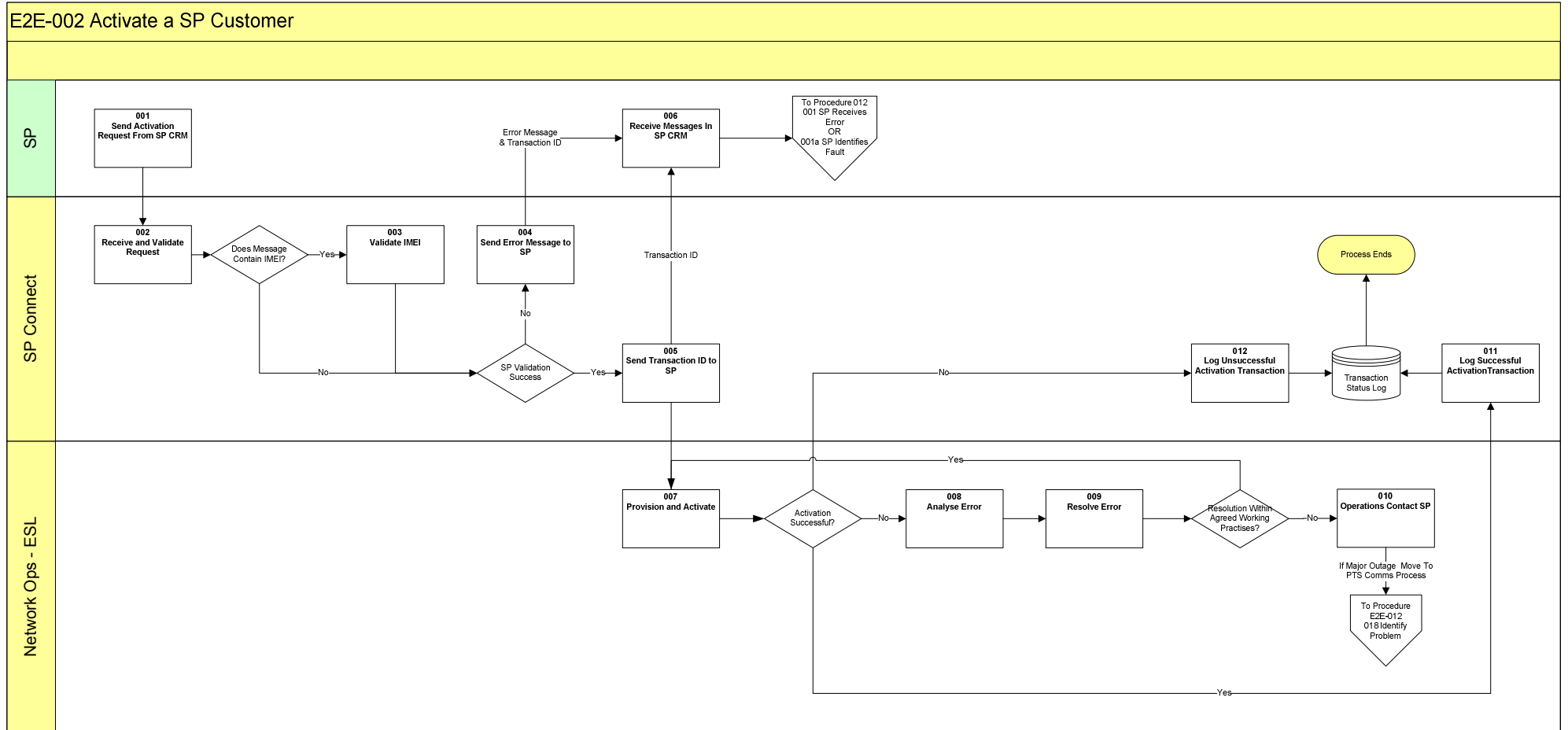

Process Name	E2E-002 Activate an SP Customer	Process Owner	
Step Id	Description		
001	Send Activation Request from SP CRM Customer requires Activation		
002	Receive and Validate Request		
003	Validate IMEI		
004	Send Error Message to SP		
005	Send Transaction ID to SP		
006	Receive Messages in SP CRM		
007	Provision and Activate Update network elements including: <ul style="list-style-type: none"> • 3DS (3 Directory Server) • Access Security Framework (ASF) • Alerts • Authentication Centre (AUC) • Common Customer View (CCV) • Equipment Identification Register (if IMEI is available) • Home Location Register (HLR) • Intelligent Network (IN) • Messaging • USIM 		
008	Analyse Error		
009	Resolve Error 1. Determine Error Type 2. Resolve within Network Operations - ESL OR 3. Pass Error Message/Code back to SP Connect, OR 4. Major System Error Pass Error Message/Code back to SP Connect, and move to PTS Communication Process		
010	Operations Contact SP 1. IF standard Transaction Error pass Error Message back to SP Connect 2. IF Major Outage OR Major Error move to PTS Comms Process		
011	Log Successful Activation Transaction 1. Receive Acknowledgement of Successful Activate from Network Operations -ESL		

	2. Complete Activation with SP CRM
012	Log Unsuccessful Activation Transaction

N.B. For data only MVNOs this process is carried out by H3G on behalf of the MVNO. In that case the USIMs are shipped to the MVNO already provisioned on the H3G network but in a suspended state so that the MVNO can control the usage of the USIM.

E2E-003 Post Sale Support of a SP Customer

E2E-003 Post Sale Support of a SP Customer

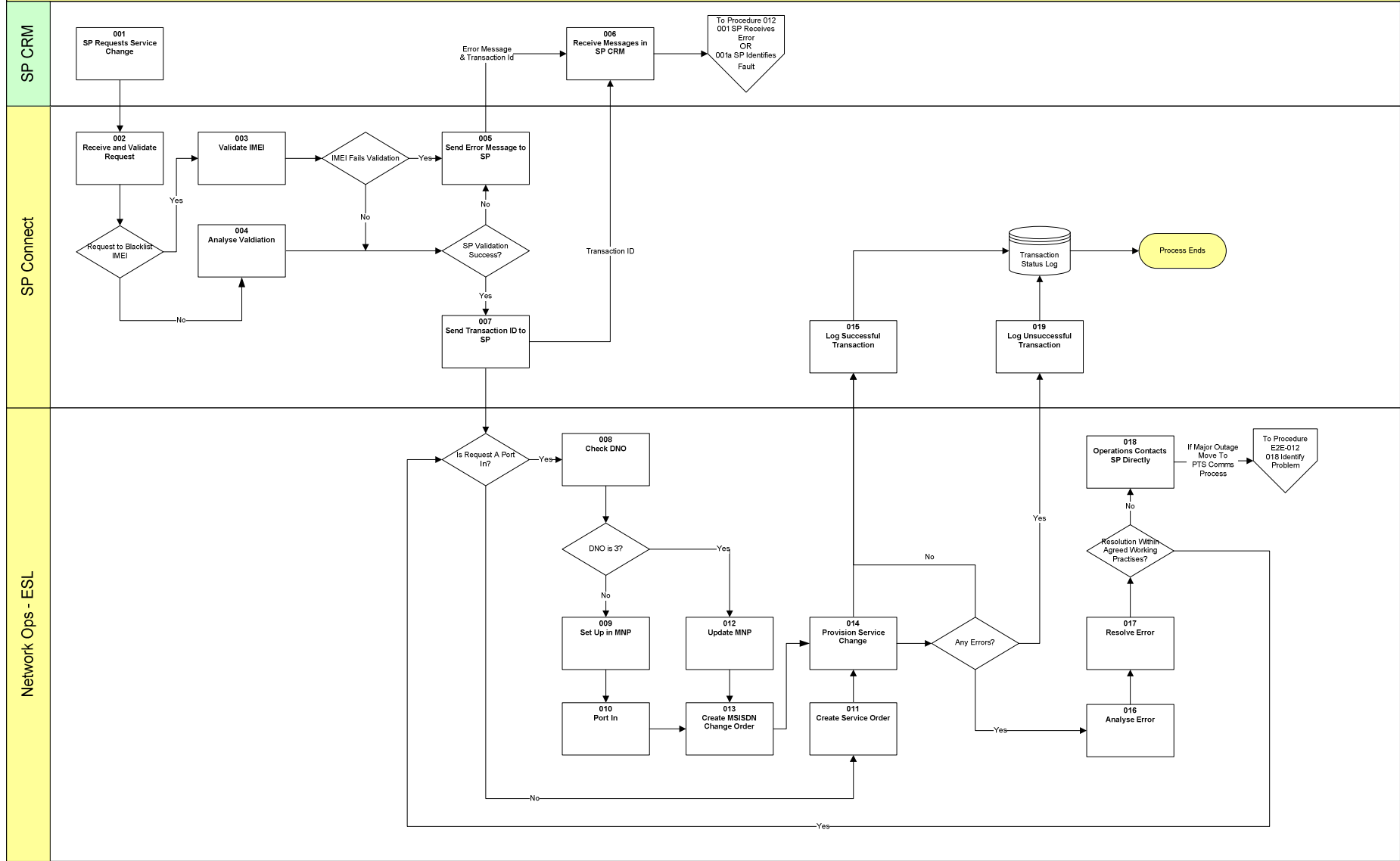

E2E-004 Provide CDRs to Service Provider

Process Name	E2E-003 Post Sale Support of a Customer	Process Owner	
Step Id	Description		
001	SP Requests Service Change		
002	Receive and Validate Request		
003	Validate IMEI		
004	Analyse Validation		
005	Send Error Messages to SP		
006	Receive Messages in SP CRM		
007	Send Transaction ID to SP		
008	Check DNO		
009	Set Up in MNP		
010	Port In		
011	Create Service Order		
012	Update MNP		
013	Create MSISDN Change Order		
014	Provision Service Change Update network elements including: <ul style="list-style-type: none"> • 3DS (3 Directory Server) • Access Security Framework (ASF) • Alerts • Authentication Centre (AUC) • Common Customer View (CCV) • Equipment Identification Register (if IMEI is available) • Home Location Register (HLR) • Intelligent Network (IN) • Messaging • USIM 		
015	Log Successful Transaction		
016	Analyse Error		
017	Resolve Error 1. Determine Error Type 2. Resolve within Network Operations - ESL OR 3. Pass Error Message/Code back to SP Connect, OR 4. Major System Error Pass Error Message/Code back to SP Connect, and move to PTS Communication Process		
018	Operations Contact SP Directly 1. IF standard Transaction Error pass Error Message back to SP Connect 2. IF Major Outage OR Major Error move to PTS Comms Process		
019	Log Unsuccessful Transaction		

E2E-004 Provide CDRs to Service Provider

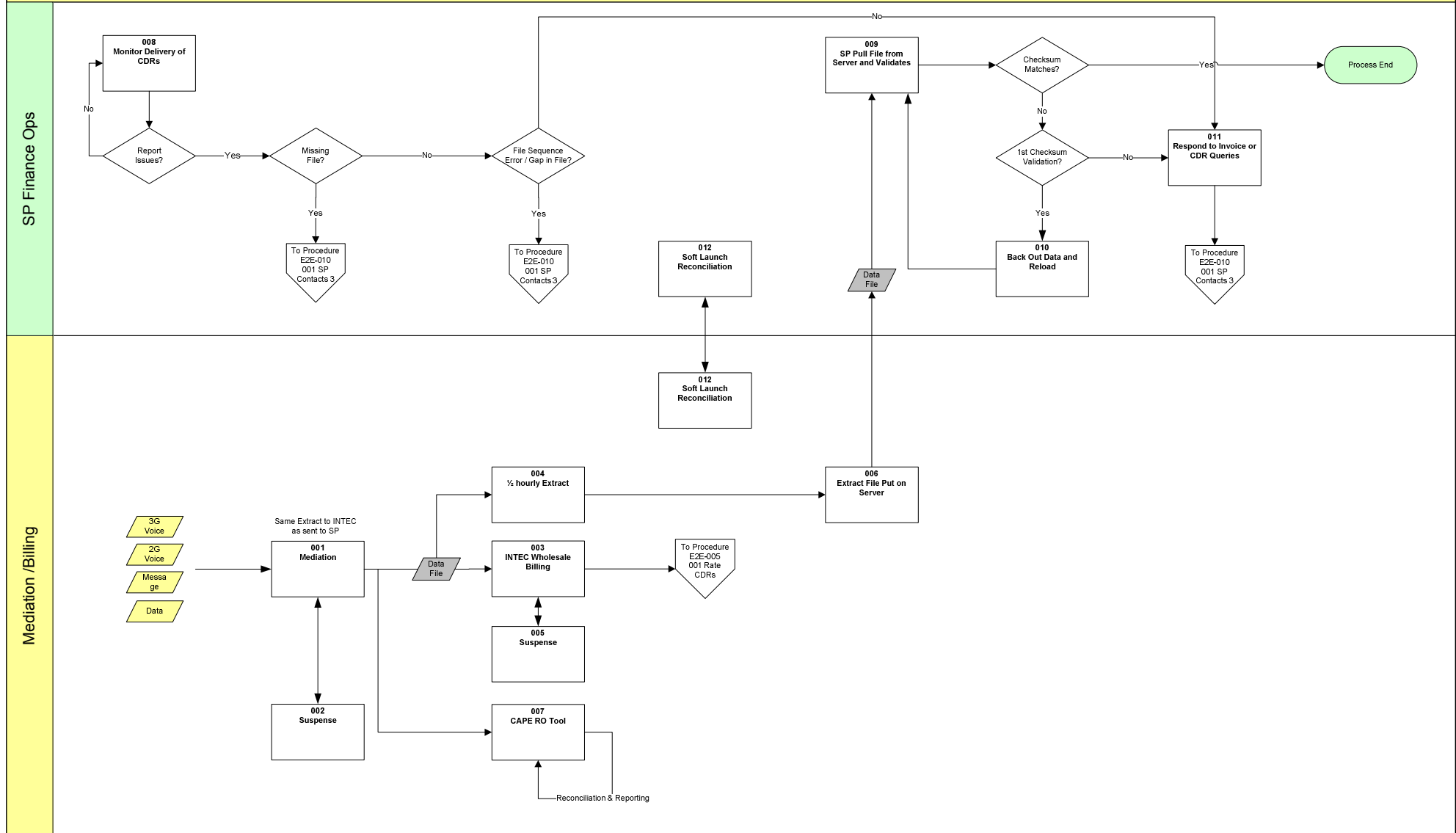

E2E-005 Invoice a Service Provider

Process Name	E2E-004 Provide CDRs to Service Provider	Process Owner	
Step Id	Description		
001	Mediation		
002	Suspense The Mediation team produce the mediation suspense report daily and analyse any potential increases in suspense and fixing - reprocessing errors. SP (MVNO) suspense records will fall under POSTMEDPROC under mediation suspense.		
003	INTEC Wholesale Billing If CDRs are in suspense then 3 is not receiving the revenue for them (although they have been sent to the SP)		
004	1/2 hourly data extract 1. Extract Wholesale Billing Records every 1/2 hour from Mediation 2. Load Wholesale Billing Extract onto server		
005	Suspense By InterConnect team		
006	Extract File Put On Server		
007	CAPE RO Tool Revenue Assurance Tool		
008	Monitor Delivery of CDRs		
009	SP Pull File from Server and Validates		
010	Back Out Data and Reload		
011	Respond to Invoice or CDR Queries		
012	Soft Launch Reconciliation This is a post launch one-off activity		

E2E-005 Invoice a Service Provider

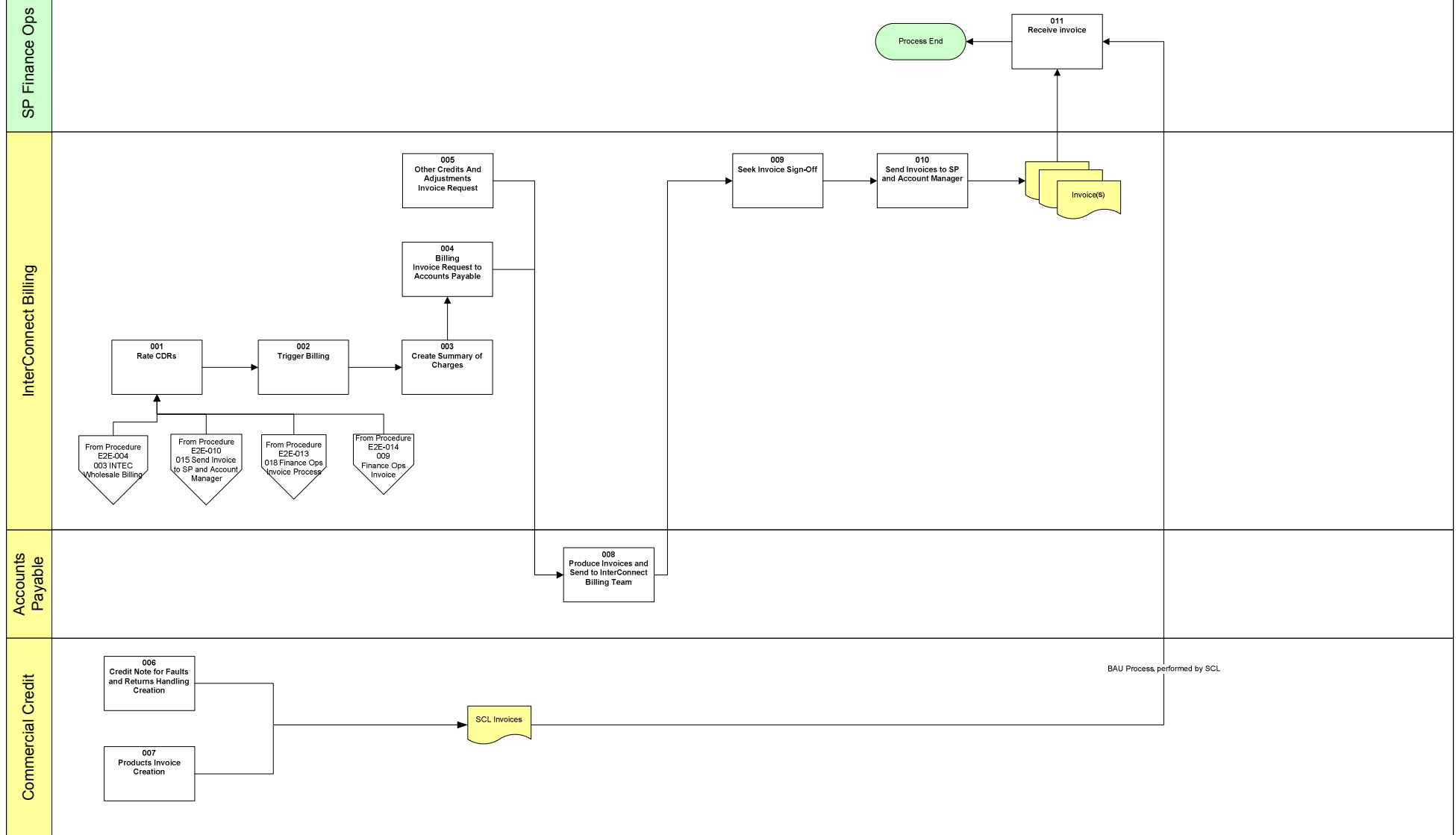

E2E-006 Lost or Stolen Process When SP Connect is Down

Process Name	E2E-005 Invoice a Service Provider	Process Owner	
Step Id	Description		
001	Rate CDRs		
002	Trigger Billing		
003	Create Summary Of Charges		
004	Billing Invoice Request to Accounts Payable 1. GL Update 2. Provide usage Charges for Invoicing 3. Calculate Average Monthly Base 4. Calculate Recurring Charges 5. Create Summary Charges 6. Invoice Request Form Completed 7. Create Invoice		
005	Other Credits and Adjustments Invoice Request 1. Receive PTS Charging Data 2. Create PTS Invoice		
006	Credit Note for Faults and Returns Handling Creation 1. Receive SCL Data 2. Create SCL Support Invoice		
007	Products Invoice Creation 1. Receive SCL Products Data 2. Create SCL Products Invoice		
008	Produce Invoices and Send to InterConnect Billing Team		
009	Seek Invoice Sign-Off		
010	Send Invoices to SP and Account Manager		
011	Receive Invoice		

E2E-006 Lost or Stolen Process When SP Connect is Down

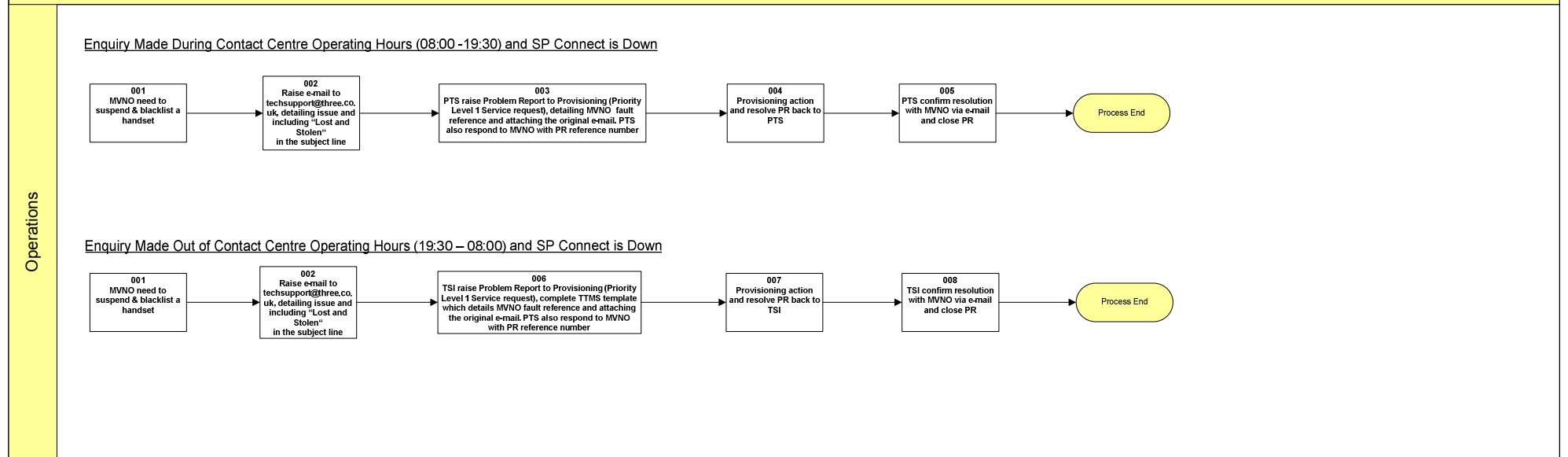

Process Name	E2E-006 Lost or Stolen Process When SP Connect is Down	Process Owner	
Step Id	Description		
001	MVNO need to suspend & blacklist a handset		
002	Raise e-mail to techsupport@three.co.uk, detailing issue and including "Lost and Stolen" in the subject line Include the following details in the email: <ul style="list-style-type: none"> • IMEI • MSISDN • ICCID (USIM serial number) 		
003	PTS raise Problem Report to Provisioning (Priority Level 1 Service request), detailing MVNO fault reference and attaching the original e-mail. PTS also respond to MVNO with PR reference number		
004	Provisioning action and resolve PR back to PTS		
005	PTS confirm resolution with MVNO via e-mail and close PR PTS will also respond to the email address received from with PR reference number along with main MVNO mailbox		
006	TSI raise Problem Report to Provisioning (Priority Level 1 Service request), complete TTMS template which details MVNO fault reference and attaching the original e-mail.		
007	Provisioning action and resolve PR back to TSI		
008	TSI confirm resolution with MVNO via e-mail and close PR PTS will also respond to the email address received from with PR reference number along with main MVNO mailbox		

TSI can only deal with lost and stolen requests out of hours when SP Connect is down.

If agents in a 3 Contact Centre use their existing tools to suspend an MVNO subscriber as part of the out of hours process then the subscriber will have their services removed to achieve the suspension as is the case for H3G subs. As that is different to the way that SPConnect suspends subscribers it means SPConnect can not be used to remove the suspension. The way SPConnect suspends a subscriber's USIM is to deactivate it on the HLR.

The TSI team supporting the out of hours service suspension process to raise a PR for PTS with specific instructions on how to suspend the USIM by submitting a service order to deactivate the associated HLR profile. This means that SPConnect can then be used to remove the suspension.

Fault Resolution Best Endeavours Timeline covers all faults (including port failures), apart from lost/stolen requests:

- Lost/Stolen (when SP Connect is down)
 - - All requests will be picked up and actioned within 4 hours at anytime of day or night (assuming SP provides 24 hour cover, 7 days a week service).
 -
 - Fault & Port Issue (24 hours a day, 7 days a week service)
 - Upon receiving SP email, an automated email is sent back to SP to acknowledge receipt.
 - All requests will be picked up within 24 hours (within opening hours of 08.00 to 19.30, each day of the week).
 - A daily email will be sent to each MVNO stating list of non-resolved issues and corresponding status of each by close of business each working day at 17:30 Monday to Friday.
- SP Escalation Route

- SP to send email to specific email address to escalate issues and cc 3 Account Manager
- Escalation email can be used:
 - When initial response of 4 hour agreed timeframe for Lost/Stolen requests has not been met.
 - When initial response of 24 hour agreed timeframe for Fault requests has not been met.
 - When initial response of 24 hour agreed timeframe for Port Failure requests has not been met.
 - When specific customer detail not covered within daily email update report after receiving confirmation PR raised but not yet received email confirming resolved.

E2E-007 Disconnect a SP Customer

E2E-007 Disconnect a SP Customer

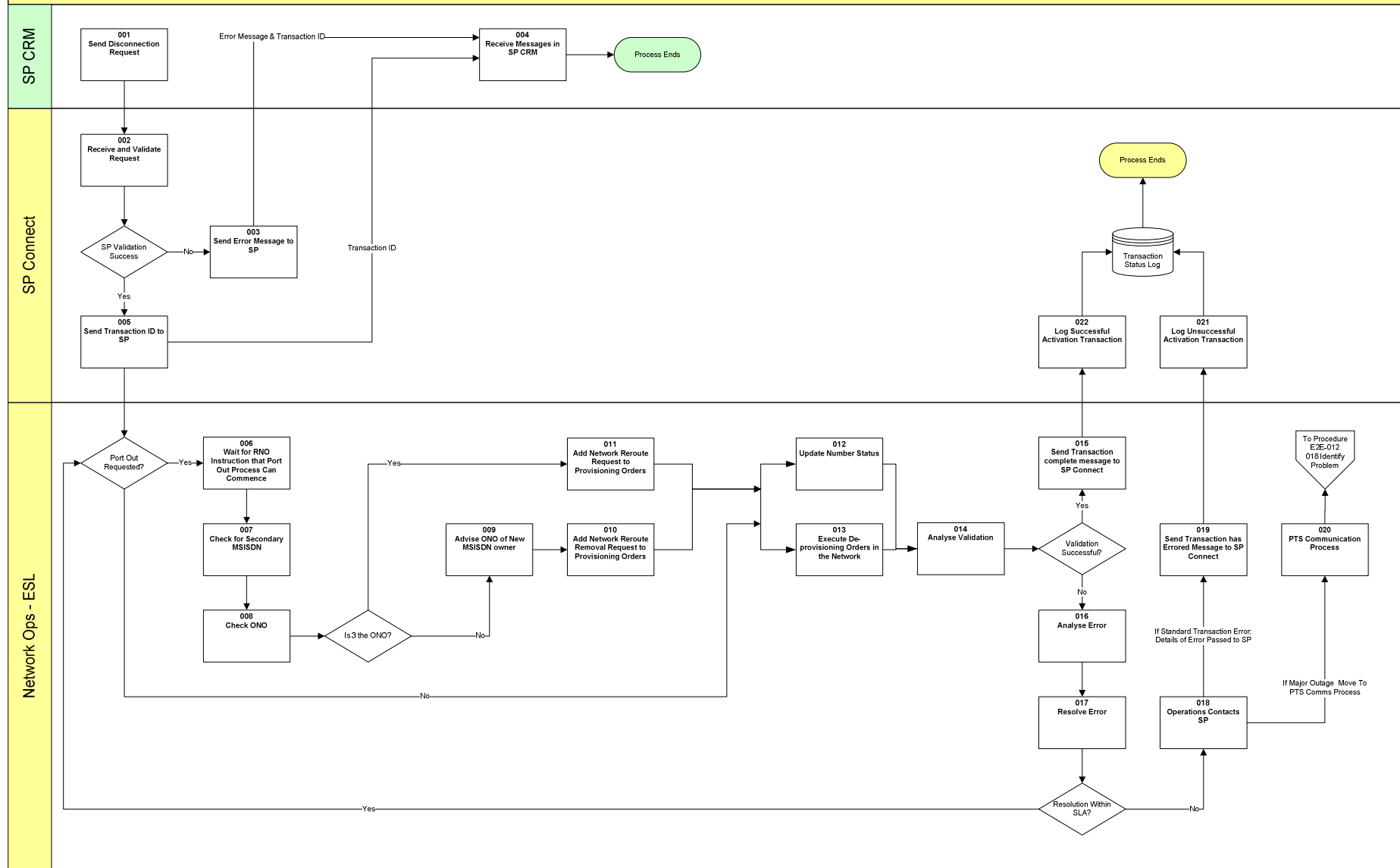

Process Name	E2E-007 Disconnect a SP Customer	Process Owner	
Step Id	Description		
001	Send Disconnection Request		
002	Receive and Validate Request		
003	Send Error Messages to SP		
004	Receive Messages in SP CRM		
005	Send Transaction ID to SP		
006	Wait for RNO Instruction that Port Out Process Can Commence		
007	Check for Secondary MSISDN		
008	Check ONO		
009	Advise ONO of New MSISDN Owner		
010	Add Network Reroute Removal Request to Provisioning Orders		
011	Add Network Reroute Request to Provisioning Orders		
012	Update Number Status		
013	Execute De-provisioning Orders in the Network		
014	Analyse Validation		
015	Send Transaction complete message to SP Connect		
016	Analyse Error		
017	Resolve Error 1. Determine Error Type 2. Resolve within Network Operations - ESL OR 3. Pass Error Message/Code back to SP Connect, OR 4. Major System Error Pass Error Message/Code back to SP Connect, and move to PTS Communication Process		
018	Operations Contact SP 1. IF standard Transaction Error pass Error Message back to SP Connect 2. IF Major Outage OR Major Error move to PTS Comms Process		
019	Send Transaction has Errored Message to SP Connect		
020	PTS Communication Process Move to PTS Communication Process		
021	Log Unsuccessful Activation Transaction		
022	Log Successful Activation Transaction		

E2E-008 Monitor Traffic for Suspect Activity Process

E2E-008 Monitor Traffic for Suspect Activity Process

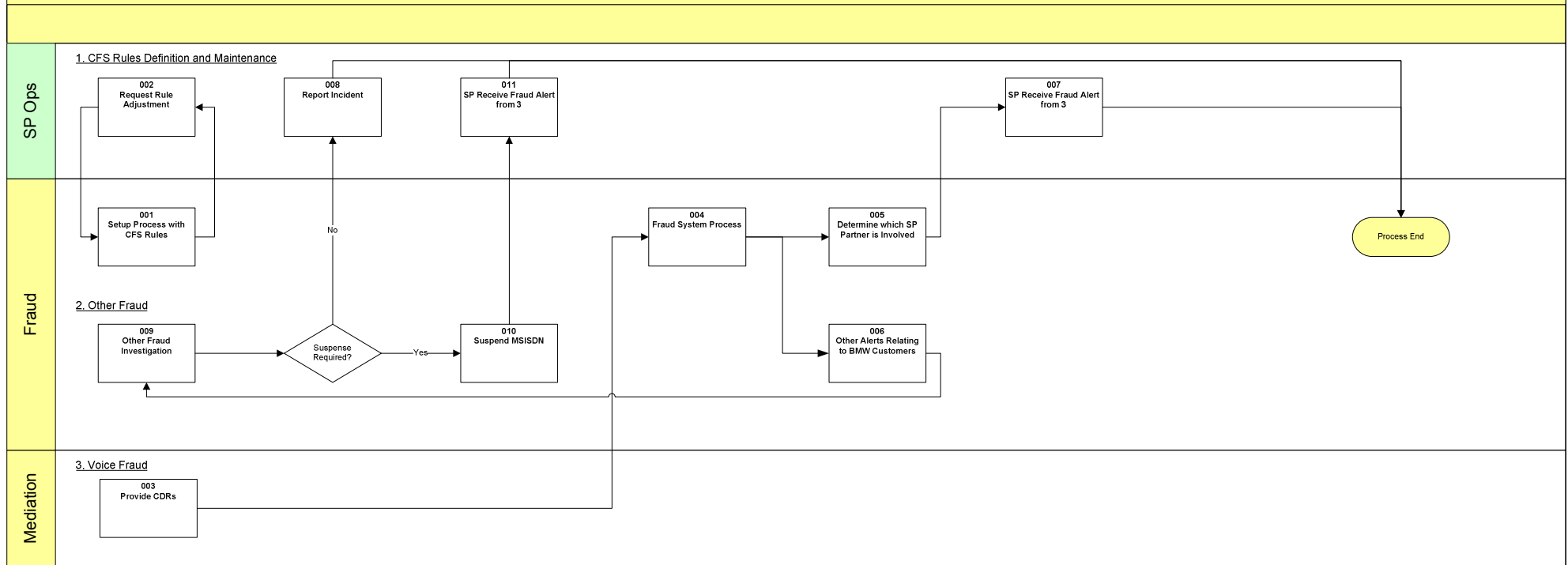

Process Name	E2E-008 Monitor Traffic for Suspect Activity Process	Process Owner	
Step Id	Description		
001	Set-up Process with CFS Rules		
002	Request Rule Adjustment		
003	Provide CDRs		
004	Fraud System Process 1. Load CDRs 2. Pseudo Rate 3. Monitor 4. Create Alert		
005	Determine which SP Partner is Involved		
006	Other Alerts Relating to BMW Customers Where the alert is triggered but 3 are unable to identify the BMW partner involved, or and alert is generated on a BMW customer from another rule, then the Fraud Operations team will investigate and if required suspend the customer. If the BMW partner is able to be identified then a note of the alert and actions taken will be sent to the alert email address.		
007	SP Receive Fraud Alert from 3 The H3G Counter Fraud System (CFS) will monitor all available CDR's and when one of the alert thresholds for an account is detected an automatic email will be generated to the alert email address. This will contain the identity of the rule triggered, and the IMSI of the account. It may also contain the MSISDN if this is available to the CFS system.		
008	Report Incident Where the H3G Fraud team has detected a suspect fraud activity through the operation of fraud detection of our own customer activity and established linkage to a BMW account, The fraud team will email a note of the alert and actions taken to the alert email address.		
009	Other Fraud Investigation		
010	Suspend MSISDN		
011	SP Receive Fraud Alert from 3 Where the H3G Fraud team has detected a suspect fraud activity through the operation of fraud detection of our own customer activity and established linkage to a BMW account, and the assessment of the activity is that it is substantial, the account will be immediately disabled. The fraud team will email a note of the alert and the actions taken to the alert email address.		

E2E-009 SP Connect Availability

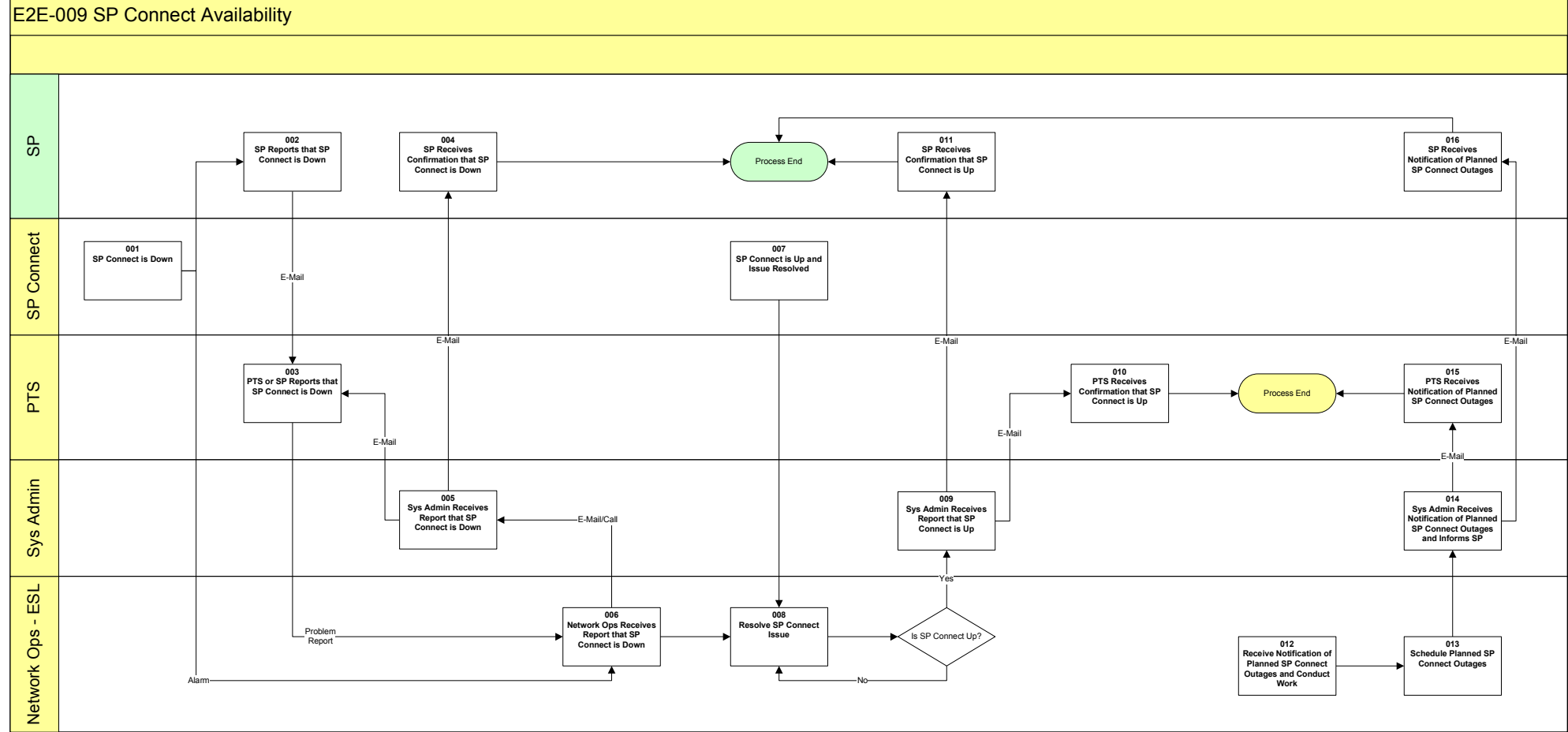

Process Name	E2E-009 SP Connect Availability	Process Owner	
Step Id	Description		
001	SP Connect is Down		
002	SP Reports that SP Connect is Down		
003	PTS or SP Reports that SP Connect is Down		
004	SP Receives Confirmation that SP Connect is Down		
005	Sys Admin Receives Report that SP Connect is Down		
006	Network Ops Receives Report that SP Connect is Down		
007	SP Connect is Up and Issue Resolved		
008	Resolve SP Connect Issue		
009	Sys Admin Receives Report that SP Connect is Up		
010	PTS Receives Confirmation that SP Connect is Up		
011	SP Receives Confirmation that SP Connect is Up		
012	Receive Notification of Planned SP Connect Outages and Conduct Work		
013	Schedule Planned SP Connect Outages		
014	Sys Admin Receives Notification of Planned SP Connect Outages and Informs SP		
015	PTS Receives Notification of Planned SP Connect Outages		
016	SP Receives Notification of Planned SP Connect Outages		

E2E-010 Respond to Invoice or CDR Queries

E2E-010 Respond to Invoice or CDR Queries

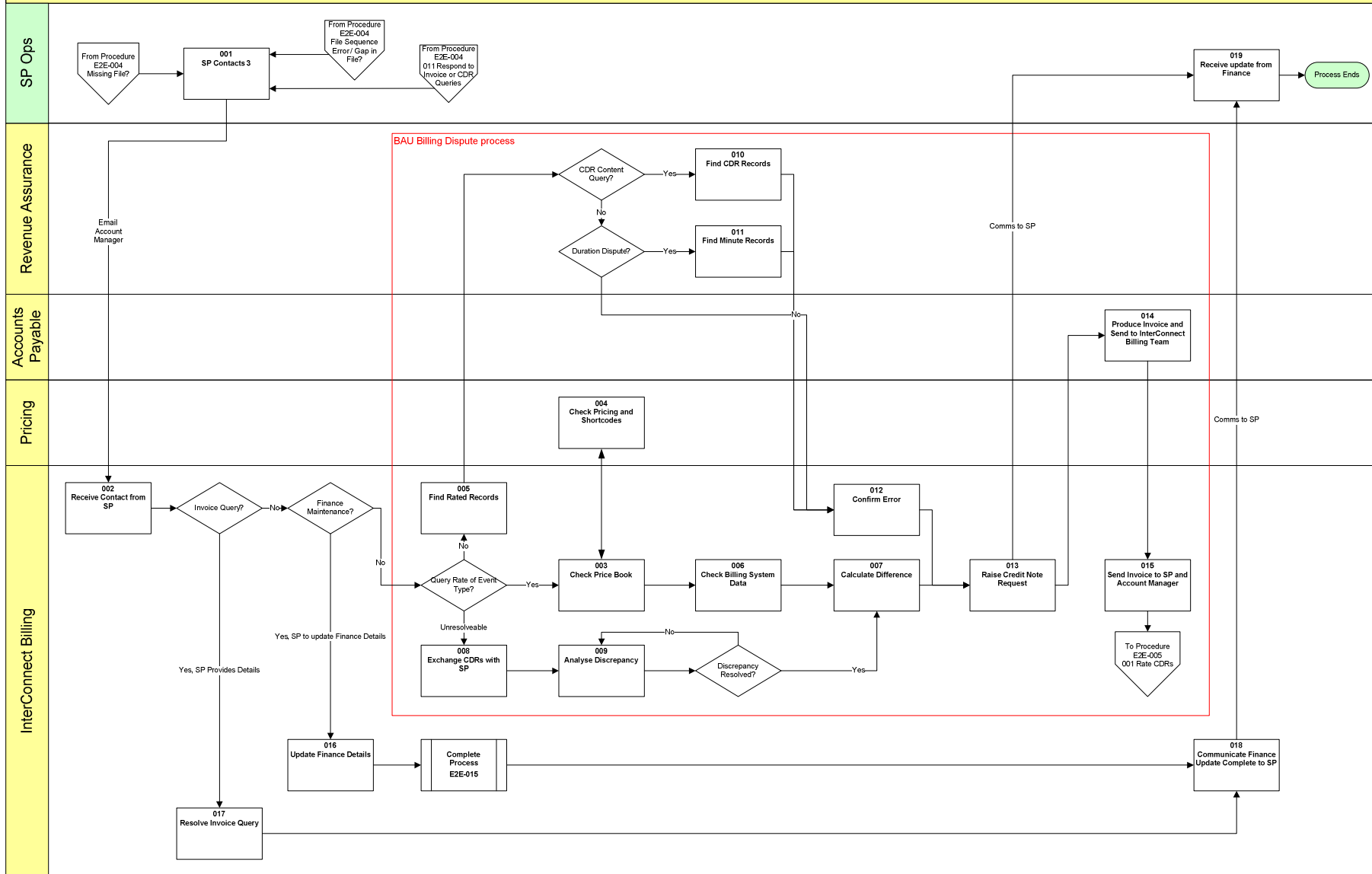

Process Name	E2E-010 Respond to Invoice or CDR Queries	Process Owner	
Step Id	Description		
001	SP Contacts 3 SP Contacts InterConnect Billing team email address and cc's Account Manager with all CDR and Invoice queries		
002	Receive Contact from SP		
003	Check Price Book Check CNP and tier configuration to check calls are in correct band. If not and a dispute is raised in the current month then re-price otherwise raise a credit note or invoice as appropriate		
004	Check Pricing and Shortcodes		
005	Find Rated Records IF NOT Query Rate of Event Type Find Rated Records		
006	Check Billing System Data		
007	Calculate Difference		
008	Exchange CDRs with SP		
009	Analyse Discrepancy		
010	Find CDR Records		
011	Find Minute Records		
012	Confirm Error		
013	Raise Credit Note Request		
014	Produce Invoice and Send to InterConnect Billing Team		
015	Send Invoice to SP and Account Manager		
016	Update Finance Details 1. Update Billing (Price Book) 2. Update Revenue Assurance		
017	Resolve Invoice Query		
018	Communicate Finance Update Complete to SP		
019	Receive update from Finance		

E2E-011 Query Transaction Status

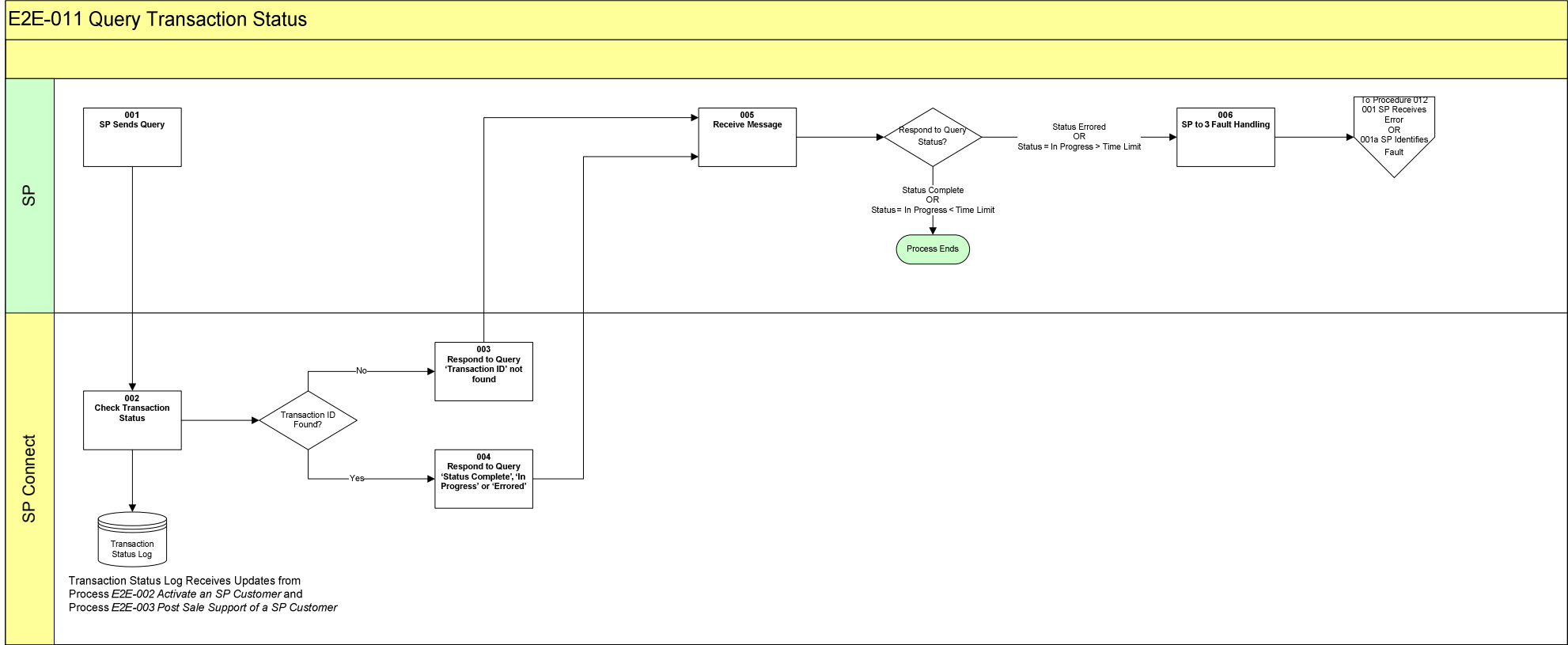

Process Name	E2E-011 Query	Process Owner	
Step Id	Description		
001	SP Sends Query		
002	Check Transaction Status Transaction Status Log Receives Updates from Process <i>E2E-002 Activate an SP Customer</i> and Process <i>E2E-003 Post Sale Support of a SP Customer</i>		
003	Respond to Query 'Transaction ID Not Found'		
004	Respond to Query 'Status Complete', 'In Progress' or 'Errored'		
005	Receive Message		
006	SP to 3 Fault Handling		

This is process the SP can follow if they want to query SP Connect to ascertain the status of a previously submitted Service Order.

E2E-012 SP to 3 Fault Handling

E2E-012 SP to 3 Fault Handling

Comms Process

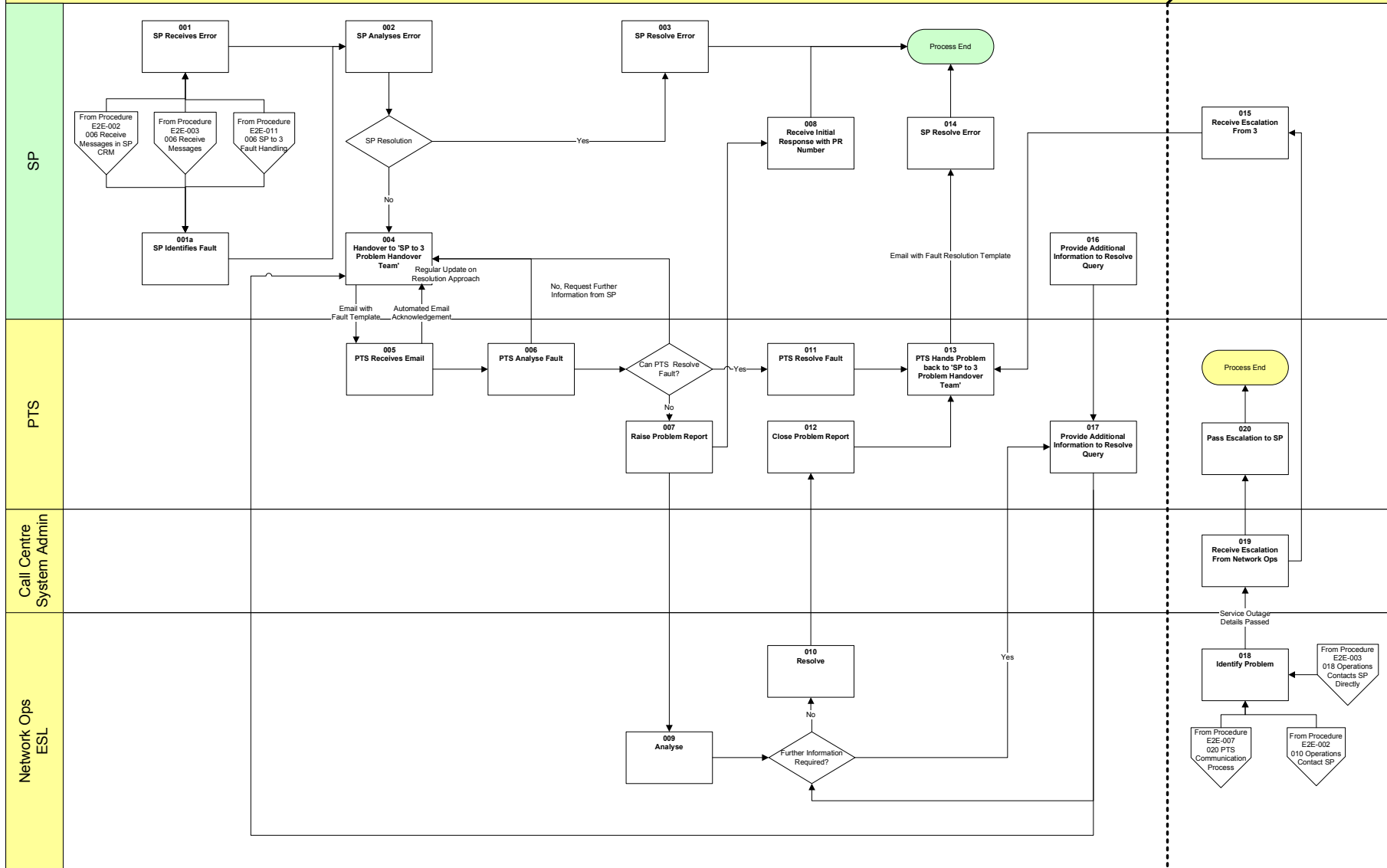

Process Name	E2E-012 SP to 3 Fault Handling	Process Owner	
Step Id	Description		
001	SP Receives Error		
001a	SP Identifies Fault		
002	SP Analyses Error 1. Uses Diagnostic PDFs to determine Problem 2. Raise Problem Report		
003	SP Resolve Error		
004	Handover to 'SP to 3 Problem Handover Team' 1. Process '3 Assigned' Problem Reports into correct format 2. Handover '3 Assigned' Problem Reports to 3 PTS. Undertaken by email and agreed template		
005	PTS Receives Email SP sends email to techsupport@three.co.uk		
006	PTS Analyse Fault Review against known outages		
007	Raise Problem Report		
008	Receive Initial Response with PR Number		
009	Analyse		
010	Resolve		
011	PTS Resolve Fault		
012	Close Problem Report		
013	PTS Hands Problem back to 'SP to 3 Problem Handover Team' Email with Fault Template		
014	SP Resolve Error		
015	Receive Escalation From 3		
016	Provide Additional Information to Resolve Query		
017	Provide Additional Information to Resolve Query		
018	Identify Problem		
019	Receive Escalation From Network Ops		
020	Pass Escalation to SP 1. Determine if SP needs to be contacted 2. Contact SP		

This is also a suitable process for raising Service Requests (SRs) for example gaining access to Service Checker in addition to being the first port of call for queries raised by the SP.

A PR will not be closed until PTS have confirmation that the issue has been fixed or the MVNO has failed to respond to requests for positive confirmation of resolution.

Processes E2E-002 Activate an SP Customer, E2E-003 Post Sale Support of a SP Customer and E2E-007 Disconnect a SP Customer only enter this process by exception if the issue cannot be resolved within the parameters of the documented process.

Fault Resolution Best Endeavours Timeline covers all faults (including port failures), apart from lost/stolen requests:

- Lost/Stolen (when SP Connect is down)
 - All requests will be picked up and actioned within 4 hours at anytime of day or night (assuming SP provides 24 hour cover, 7 days a week service).
- Fault & Port Issue (24 hours a day, 7 days a week service)
 - Upon receiving SP email, an automated email is sent back to SP to acknowledge receipt.
 - All requests will be picked up within 24 hours (within opening hours of 08.00 to 19.30, each day of the week).
 - A daily email will be sent to each MVNO stating list of non-resolved issues and corresponding status of each by close of business each working day at 17:30 Monday to Friday.
- SP Escalation Route
 - SP to send email to specific email address to escalate issues and cc 3 Account Manager
- Escalation email can be used:
 - When initial response of 4 hour agreed timeframe for Lost/Stolen requests has not been met.
 - When initial response of 24 hour agreed timeframe for Fault requests has not been met.
 - When initial response of 24 hour agreed timeframe for Port Failure requests has not been met.
 - When specific customer detail not covered within daily email update report after receiving confirmation PR raised but not yet received email confirming resolved.

E2E-013 Supply Chain Logistics Ordering

E2E-013 Supply Chain Logistics Ordering

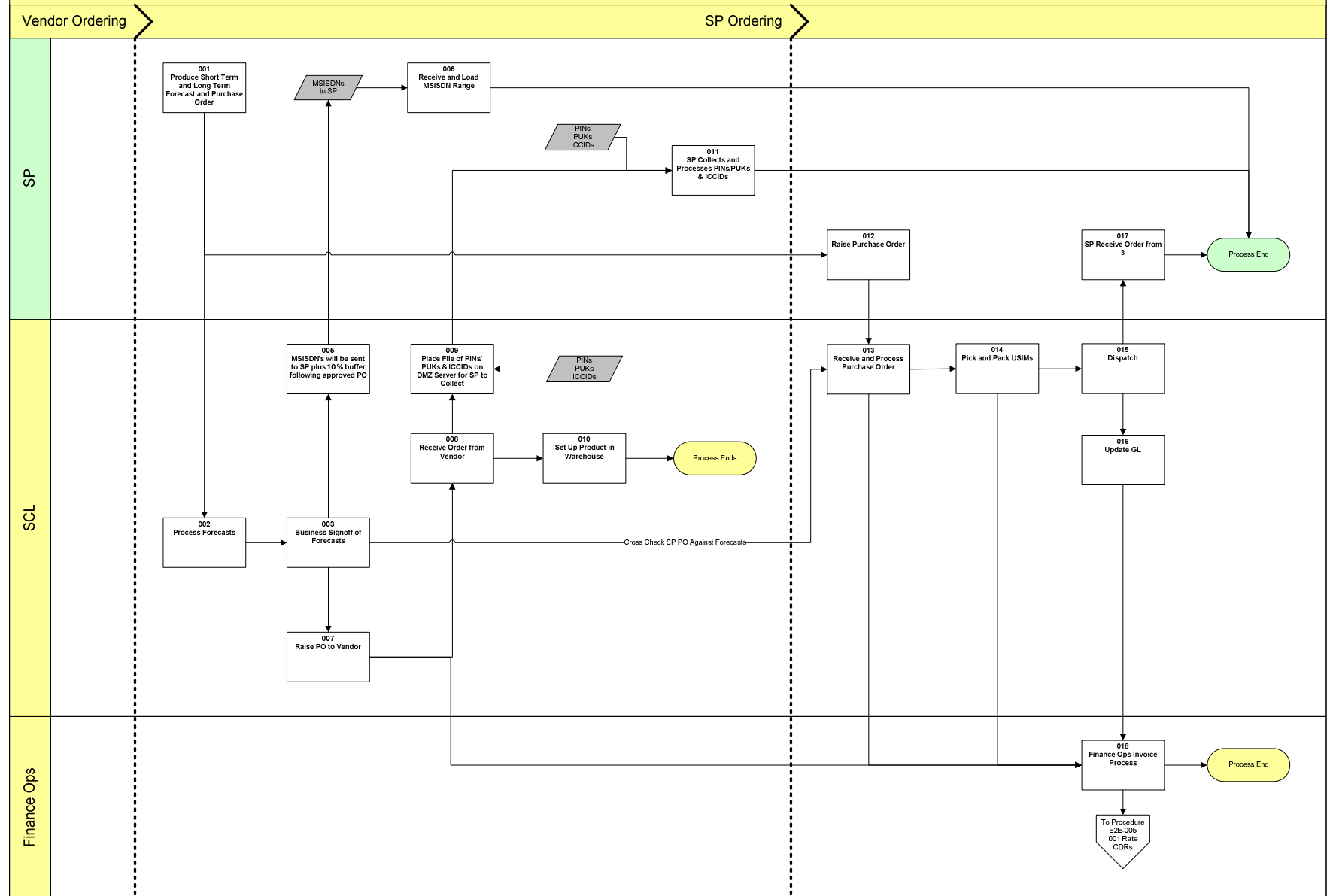

Process Name	E2E-013 Supply Chain Logistics Ordering	Process Owner	Mark Williams (USIM Manager), Neil Watson (Supply Chain Logistics)
Step Id	Description		
001	Produce Short Term and Long Term Forecast and Purchase Order 1. SP complete 6 months rolling forecasts 2. SP sends Forecasts to 3 3. SP sends PO 4. 3 complete internal PO to secure product for SP 5. 3 will advise SP of delivery date - approx 4 - 6 weeks		
002	Process Forecasts 1. Receive Forecasts 2. Process Forecasts		
003	Business Signoff of Forecasts		
004	Raise PO for Product Vendor (e.g. Gemalto for USIMs)		
005	MSISDN's will be sent to SP plus 10 % buffer following approved PO		
006	Receive and Load MSISDN Range		
007	Raise PO to Vendor		
008	Receive Order from Vendor		
009	Place File of PINs/PUKs & ICCIDs on DMZ Server for SP to Collect		
010	Set Up Product in Warehouse This is a business as usual process that includes: <ul style="list-style-type: none"> • Finance assigning a purchase order • A part number being created in Red Prairie (Warehouse Management System) and Oracle to enable Sales to order the new product (SIM cards only in this instance) 		
011	SP Collects and Processes PINs/PUKs & ICCIDs		
012	Raise Purchase Order 1. SP Logistics Raises Purchase Order 2. Send PO to SCL		
013	Receive and Process Purchase Order 1. Check Credit Limits 2. Check Forecasting		
014	Pick and Pack USIMS		
015	Dispatch		
016	Update GL		
017	SP Receive Order from 3		
018	Finance Ops Invoice Process		

E2E-014 SCL Returns and Faults

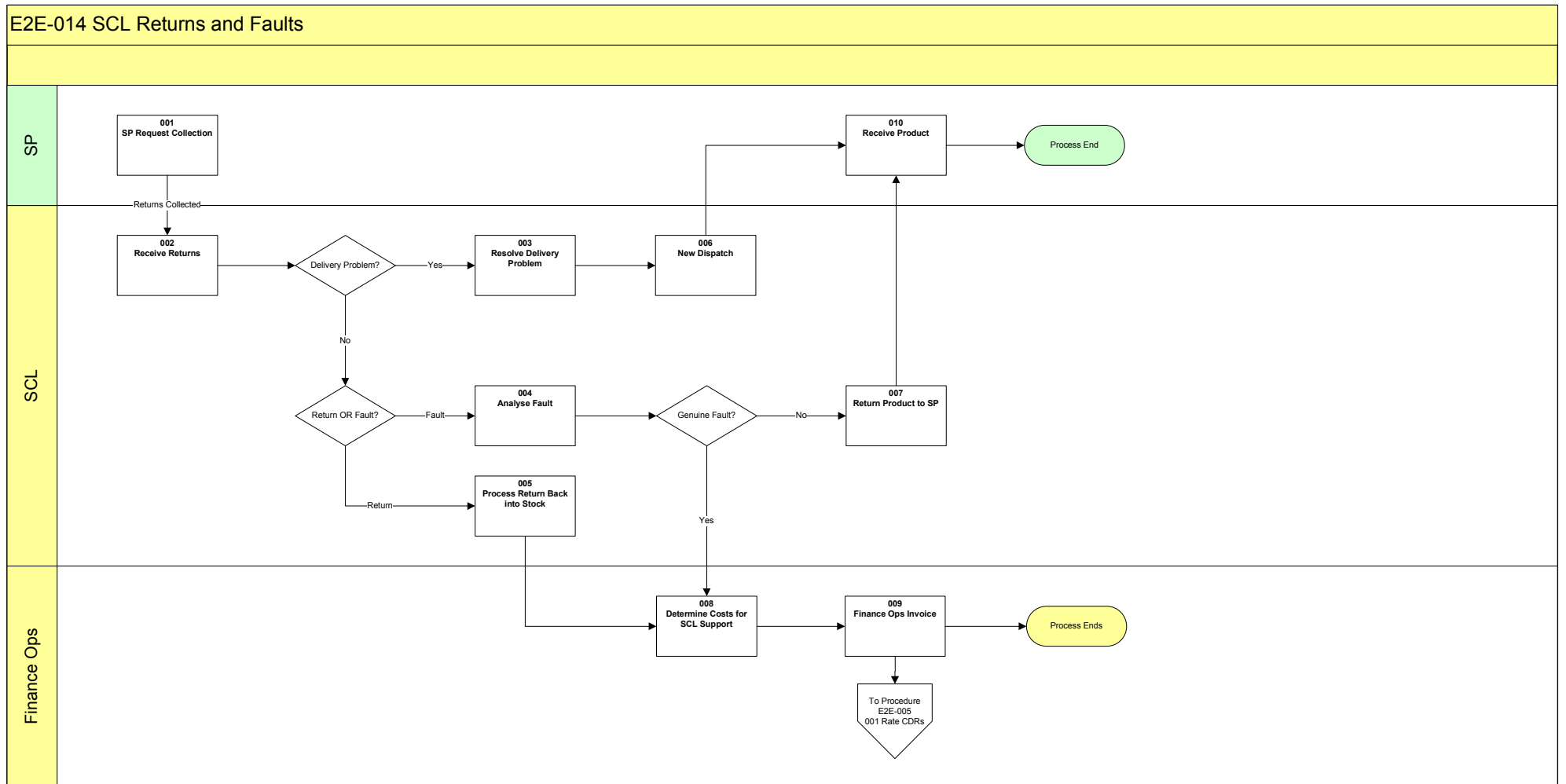

Process Name	E2E-014 SCL Returns and Faults	Process Owner	Neil Watson (Supply Chain Logistics)
Step Id	Description		
001	SP Request Collection		
002	Receive Returns		
003	Resolve Delivery Problem		
004	Analyse Fault		
005	Process Return Back Into Stock		
006	New Dispatch		
007	Return Product to SP		
008	Determine Costs for SCL Support		
009	Finance Ops Invoice		
010	Receive Product		

3 Transfer ownership of USIMs to SP when shipped.

E2E-015 Update Finance Details

E2E-015 Update Finance Details

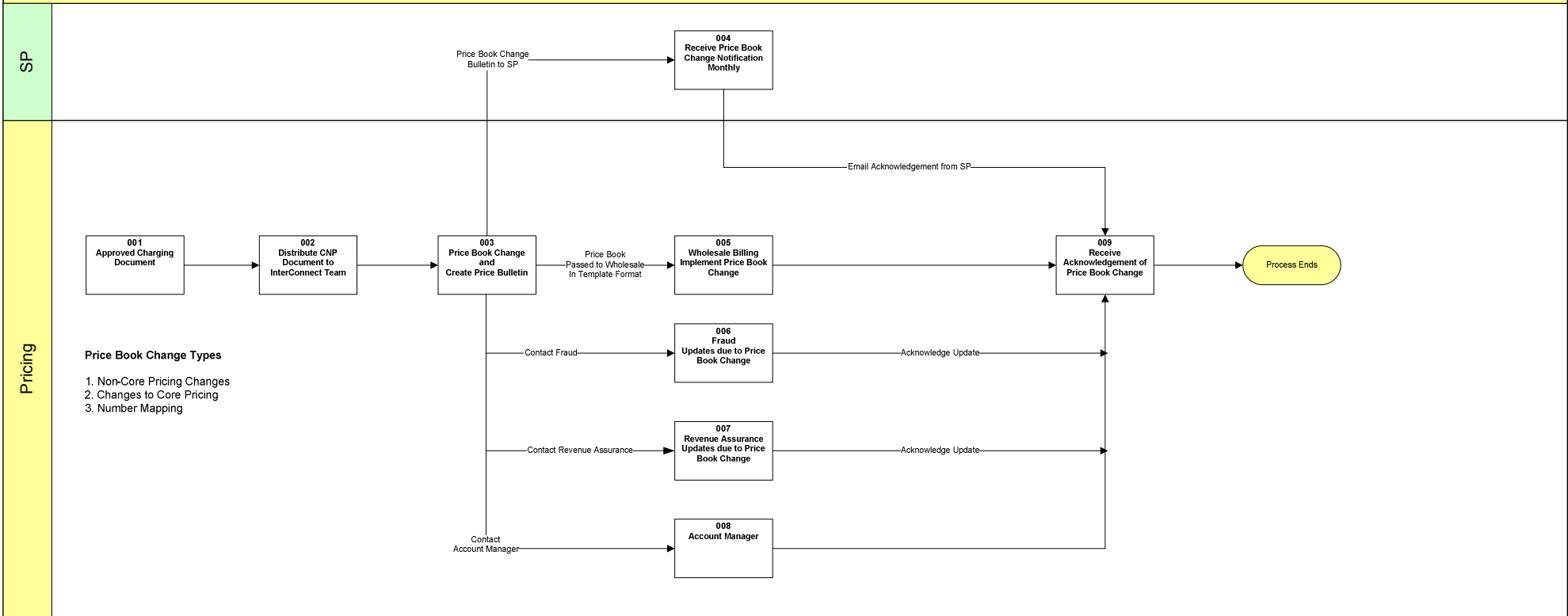

Process Name	E2E-015 Update Finance Details	Process Owner	Stuart Ward (Fraud), Tracey Howett (MVNO Manager), Peter Haughey (Finance), Stephen Ness (Pricing)
Step Id	Description		
Pre-001	Retail shortcode and numbers ranges are setup in the Price Book (Wholesale prices pre-configured at the same time as Retail thus no Wholesale specific approvals process is required) Price Book distributed to Interconnect team and SP monthly		
001	Approved Charging Document 1. Determine Price Book Change (Non-Core Pricing, Core Pricing, Number Mapping) 2. Raise Charging Document		
002	Distribute CNP Document to InterConnect Team		
003	Price Book Change and Create Price Bulletin 1. Pricing Bulletin to Wholesale Partner. Need Lead Time of 24 hours minimum 2. Price Book Change passed to Retail Billing 3. Price Book Change passed to Fraud 4. Price Book Change passed to Revenue Assurance 5. Price Book Change passed to Account Manager 6. Pricing Bulletin passed to Wholesale Billing		
004	Receive Price Book Change Notification Monthly		
005	Wholesale Billing Implement Price Book Change 1. Populate Auto Load Template 2. Load Auto Load Template and set to status LOADED. 3. Send confirmation to Pricing		
006	Fraud Updates due to Price Book Change		
007	Revenue Assurance Updates due to Price Book Change		
008	Account Manager Account Manager Acknowledges Price Book Change		
009	Receive Acknowledgement of Price Book Change		

E2E-017 Customer Calls 3 Instead of MVNO in Error

E2E-017 Customer Calls 3 Instead of MVNO in Error

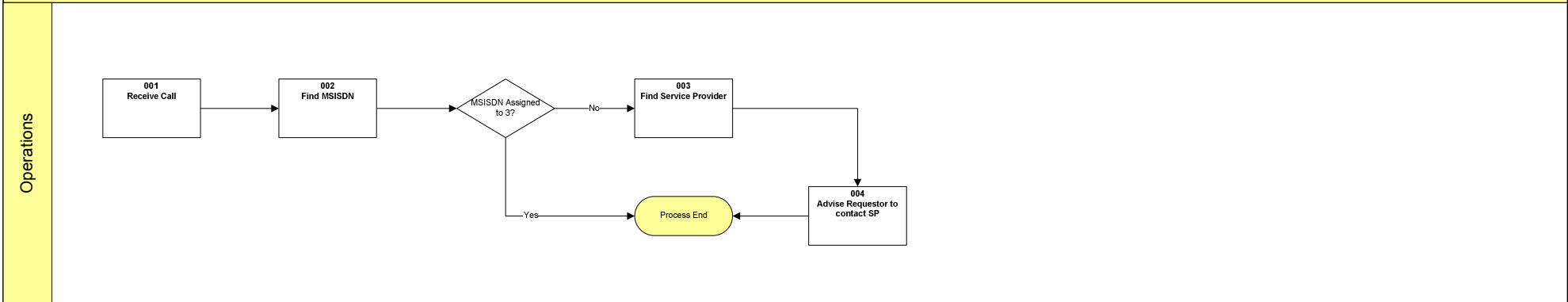

Process Name	E2E-017 Customer Calls 3 Instead of MVNO in Error	Process Owner	James Calvert (Contact Centre), Alison McMeekin (Contact Centre)
Step Id	Description		
001	Receive Call SP Customer OR Law/Regulatory Official contacts Glasgow Office		
002	Find MSISDN 1. 3 CSR finds MSISDN on CRM System 2. Determine if MSISDN belongs to 3 OR SP		
003	Find Service Provider If MSISDN belongs to SP, CSR finds which SP		
004	Advise Requestor to contact SP If call is a Law or Regulatory Request, 3 advisor informs requestor to contact SP Directly.		

This process involves an SP's customer calling 3 when they should be calling their SP for support. 3 will redirect the customer back to their SP help.

GLOSSARY

Term	Definition
3DS	3 Directory Server
AoC	Advice of Charge
A/R	Accounts Receivable
BAU	Business As Usual
BMI	Billing & Mediation Interface
BMW	Business Markets Wholesale
BRT	Business Readiness Testing
CAPE RO Tool	Revenue Assurance Tool
CCC	Customer Contact Centre
CDR	Call Data Record
CFS	Counter Fraud System
CNP	Charging Number Prefix
CPT	Charge Period Type
CRM	Customer Relationship Management
CSR	Customer Services Representative
DNO	Donating Network Operator
ESL	Ericsson Services Limited (for systems implementation and IT development)
EU	European Union
GL	General Ledger
H3G	Hutchison 3G
HLR	Home Location Register
ICCID	Integrated Circuit Card ID (USIM serial number)
Ict	InterConnect
ID	Identification
IMEI	International Mobile Equipment Identity
ISD	InterConnect Settlements Department
MNP	Mobile Number Portability
MSISDN	Mobile Subscriber ISDN Number
MVNO	Mobile Virtual Network Operator
NOP	Network Operators
OFCOM	Office of Communications
ONO	Other Network Operator

PDF	Problem Determination File
PO	Purchase Order
PR	Problem Report (Trouble Ticket)
PTS	Porting and Technical Support
RNO	Recipient Network Operator
SCL	Supply Chain Logistics
SDR	Special Drawing Rights
SIM	Subscriber Identity Module
SMS	Short Message Service (aka a text message)
SP	Service Provider
TCM	Tier CNP Membership
TSI	Technical Services India
USIM	Universal Subscriber Identity Module
WEU	Wholesale End User
DMZ	De-Militarised Zone (Outside H3G Firewall)

SCHEDULE 6

USIMs

PART A – USIM ORDERING FORECAST

DMVNO Name:

DMVNO Name:

Order Month 2009/10	Forecast	PO Number	Delivery Month
January			
February			
March			
April			
May			
June			
July			
August			
September			
October			
November			
December			

Rolling Forecast Variance

Month 1	Month 2	Month 3	Month 4	Month 5	Month 6
Fixed	Fixed	(+ or -) 50 %	(+ or -) 50 %	(+ or -) 100 %	(+ or -) 100 %

Sign Off Approval

On Behalf of DMVNO	
Signature:	
Print Name:	
Date:	

PART B – TERMS OF USIM PURCHASE

This schedule sets out the terms of purchase of USIMs between the Company and H3G under the Wholesale Services Agreement (the “Agreement”). Defined terms in this schedule shall have the same meaning as in the Agreement. The following definitions shall also apply to this schedule:

Claim: shall mean any legal actions, claims or demands brought against the Company by any third party arising from the Company’s (or its subcontractors’ or agents’) possession, use or sale of the USIM and/or the provision of any services or the results of any services which infringes the Intellectual Property Rights of a third party;

Documentation: shall mean the descriptive materials supplied by H3G with USIMs (in hard and/or soft copy including CD-ROM format), including but not restricted to operating instructions or manuals, non-proprietary specifications, test specifications, repair, service and/or USIM descriptions, print/report descriptions, drawings, technical information and other documents, which are associated with the USIM supplied and services performed by H3G for the Company;

Purchase Order: shall mean a purchase order for USIMs, including quantity and unit prices for each USIM type that will be issued by the Company, and the following wording shall be deemed to be included in such Purchase Order: “This Purchase Order is issued pursuant to, and made on the terms of the Wholesale Services Agreement”;

USIM: shall mean Universal Subscriber Identity Module and the Universal Integrated Circuit Card (ICCD) as ordered and /or purchased by the Company.

1. SCOPE AND ORDERING

- 1.1. A Purchase Order, once issued by the Company in accordance with these terms and the Agreement, shall form a contract between the Company and H3G, for the supply of the USIMs detailed therein in accordance with the terms and conditions specified therein and the terms of this schedule except that in relation to the incorporation of the terms of this schedule, all references to this schedule or these terms shall be read as references to such Purchase Order.
- 1.2. H3G and the Company may mutually agree to variations or to specific terms applicable to a particular Purchase Order, which shall not otherwise affect the terms of this schedule, any other Purchase Order or the Agreement.
- 1.3. The Company shall be liable to pay H3G for all USIMs delivered pursuant to these terms, in accordance with the terms of payment set out in Clause [●] herein.

2. DELIVERY QUANTITY AND CONDITION

- 2.1. Upon delivery of the USIMs to the delivery site (specified by the Company in its Purchase Order) the Company shall inspect the exterior of the packaging of the USIMs to determine if the USIMs appear to be in undamaged condition.

- 2.2. Acceptance of the delivery quantity shall be deemed to have occurred if H3G is not notified of any discrepancy in delivery quantity or of damage to the exterior of the packaging of the USIMs by the Company within ten (10) days of delivery.
- 2.3. [If upon inspection the Company detects any USIMs with a defect, the Company shall inform H3G, in response to which H3G shall provide suitable replacements for the relevant defective USIMs] **[NOTE: H3G TO CONFIRM]**

3. INVOICING AND TERMS OF PAYMENT

- 3.1. H3G shall be entitled to invoice the Company for USIMs from the date of delivery of such USIMs.
- 3.2. All payments due under these terms shall be made to the account notified on the relevant invoice of the invoicing party within thirty (30) days of the date of such valid invoice.
- 3.3. All prices are exclusive of value added tax, sales tax and any other applicable taxes and duties, which shall be payable, where applicable, by the Company at the rate and in the manner from time to time prescribed by law.
- 3.4. If withholding taxes are payable, the Company shall promptly notify H3G of the obligation to pay such taxes, and thereafter shall withhold such sums from payments due to H3G and pay such amounts to the relevant authorities in accordance with the applicable laws, and shall provide to H3G any and all withholding tax certificates.
- 3.5. Any amount which is paid by either party later than the date on which such sum first became due and payable under these terms shall be subject to Clause [●].

4. INTELLECTUAL PROPERTY RIGHTS

4.1. USIM

- a). Copies. The Company shall have no right to copy, in whole or in part, the software in the USIM (the "Software") (except as required for back-up, disaster-recovery and archival use) and shall not sublicense, sell, offer for sale, lease, loan, transfer or otherwise disseminate the Software, in whole or in part.
 - b). Modifications. The Company agrees that, except as permitted under the Copyright and Related Rights Act 2000, only H3G shall have the right to alter, maintain, enhance or otherwise modify the USIM or the Software. The Company agrees not derive or attempt to derive the source code or create derivative works therefrom, translate in part or in whole the object code of the Software by any means and in any form, and shall not authorise any parent, subsidiary, affiliated entities, or third party to do any of the above.
- 4.2. H3G shall retain ownership of all Intellectual Property Rights in the Documentation. H3G hereby grants to the Company a non-exclusive, irrevocable, royalty free and perpetual licence to use and copy any element of the Documentation that is required by the Company to enable it to use, install,

repair and maintain the USIM. The Company agrees that the Documentation shall be treated as the Confidential Information of H3G and shall be subject to the provisions of Clause 23 of the Agreement.

4.3. The Company shall:

- 4.3.1. not provide or make any part of the Documentation available to any person save as permitted under these terms and conditions; and
- 4.3.2. when making permitted copies transfer to each copy any copyright or other notice of proprietary rights on the Documentation.

4.4. Intellectual Property Rights Infringement

- 4.4.1. H3G or its USIM supplier shall have, at its discretion, the sole control of the defence of any Claim and all negotiations for settlement or compromise.
- 4.4.2. If a Claim is made, H3G may:
 - 4.4.2.1. replace or modify the infringing material contained in each part of the USIM or any product provided as part of the Services so that it is non-infringing, provided that any replacement or modification functions and performs at least as well as the infringing material and complies with any relevant specification or other requirements of these terms. H3G shall ensure that no interruption to the operation of the USIM or provision of the Services occurs during modification or replacement; or
 - 4.4.2.2. obtain the right for the Company lawfully to possess and use the relevant part of the USIM, and the Documentation and to exercise the rights granted under these terms.
- 4.4.3. Clause 4.4.2 shall not apply to the extent that the claim for infringement is based on:
 - (a) any unauthorised modification of the USIM, or
 - (b) use by the Company of the USIM for purposes other than that it was designed for, or
 - (c) use in conjunction with other equipment or software not approved by H3G or its USIM supplier (which when combined with the USIM causes the infringement).
- 4.4.4. To the extent that a third party makes a claim of infringement based on the exceptions specified in Clause 4.4.3, against H3G or the Company, the Company shall indemnify H3G in respect of any cost, loss or damage arising out of such action.

SCHEDULE 7

BROADBAND DETAIL RECORDS

Field Name	Start Position	Length	Description	Sample Values (Replace all X's by spaces)
Classification	1	14	Determines the business unit classification within H3G.	BM01XXXXXXXXXX
Record Sequence Number	15	15	Unique record number used to identify a particular usage event.	167XXXXXXXXXXXX
Record Type	30	4	Indicates the type of record: complete or partial. 0199 - complete 0299 - partial *Only complete records will be supplied.	0199
Event Start Date	34	8	Yyyymmdd – Year, month and day	20060401
Event Start Time	42	8	hhmmss00 - hour, minutes & seconds.	05102800
Event Size	50	10	hhhhmmssmi - hour, minutes, seconds and milliseconds	0000000100
Service Provider Identifier	116	40	The unique identified of the Service Provider. This will be the same for every record received by a Service Provider.	72000000000XXXXXXXXXX XXXXXXXXXXXXXXXXXXXX
Event Type	156	8	Specifies the event type of the record. (The possible value is PSD1)	PSD1XXXX
Network Time	165	8	Always set to 23595999.	23595999
	173	4	Reserved for future use.	
Data Volume	177	10	Data volume will be populated for MMS	1024XXXXXX

Data Unit	187	8	Data unit will be populated for MMS	BYTESXXX
	195	21	Reserved for future use.	
IMSI	216	15	The IMSI of the charged party.	234200900096713
Full Path Code	231	3	One of the attributes used to identify the Event Type. (300 - HPLMN GGSN Session, 316 - HPLMN GGSN Session Event, 320 - HPLMN GGSN Session Durat)	300
Session ID	234	40	Network based session identifier used to filter out possible duplicate records.	104447782000007AABA QwE2B3jWQEMDIGsGEBFKc
BTon Code	277	4	One of the attributes used to identify the Event Type.	XXXX
Original CDR Filename	391	60	The name of the file produced by the network/service layer that included the record.	MED_BIL_CF0005_GSM_ IN_20060518151320.DAT
	451	14	Reserved for future use	

SCHEDULE 8

NATIONAL BROADBAND SCHEME COVERAGE AREA

Broadband Coverage by ED

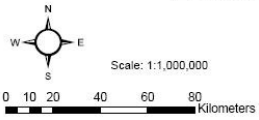

Legend

White Area

Black Area

Please refer to the ITT documents for the definition of black and white areas

County Boundary

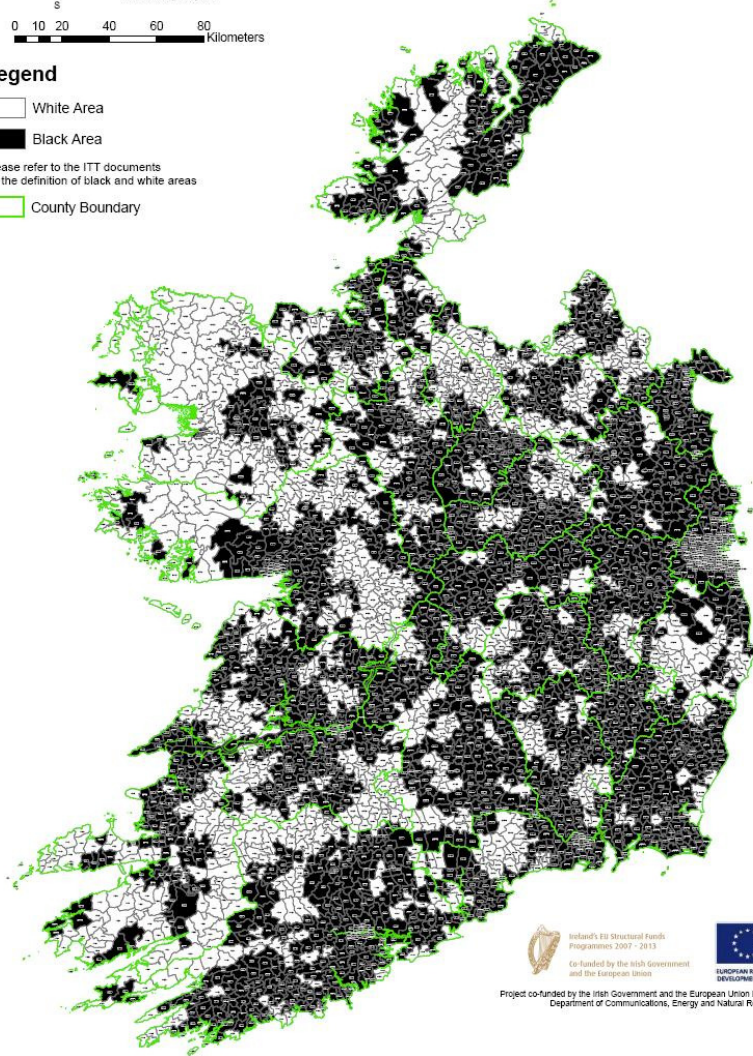

 Ireland's EU Structural Funds Programmes 2007 - 2013
Co-funded by the Irish Government and the European Union

 EUROPEAN REGIONAL DEVELOPMENT FUND

Project co-funded by the Irish Government and the European Union in association with the Department of Communications, Energy and Natural Resources

List of EDs to be covered by the NBS

County	ED Name	ED Reference	Status
CARLOW	CLONMORE DED	17014	White
CARLOW	COONOGUE DED	17015	White
CARLOW	HACKETSTOWN DED	17022	White
CARLOW	HAROLDSTOWN DED	17023	White
CARLOW	RIDGE DED	17043	White
CARLOW	TIKNOCK DED	17048	White
CAVAN	ARDUE DED	27001	White
CAVAN	BALLYMACHUGH DED	27009	White
CAVAN	BALLYMAGAUAN DED	27010	White
CAVAN	BAWNBOY DED	27011	White
CAVAN	BENBRACK DED	27014	White
CAVAN	BILBERRY DED	27015	White
CAVAN	CANNINGSTOWN DED	27018	White
CAVAN	CARN DED	27019	White
CAVAN	CARRAFIN DED	27021	White
CAVAN	CASTLERAHAN DED	27022	White
CAVAN	CASTLESAUNDERSON DED	27023	White
CAVAN	COOTEHILL RURAL DED	27027	White
CAVAN	CORR DED	27029	White
CAVAN	CORRANEARY DED	27030	White
CAVAN	CROSSBANE DED	27031	White
CAVAN	CROSSDONEY DED	27032	White
CAVAN	DERRYLAHAN DED	27037	White
CAVAN	DERRYNANANTA DED	27038	White
CAVAN	DIAMOND DED	27039	White
CAVAN	DOOGARY DED	27040	White
CAVAN	DRUMANESPICK DED	27042	White
CAVAN	DRUMCARN DED	27044	White

CAVAN	DRUMLUMMAN DED	27045	White
CAVAN	DUNMAKEEVER DED	27047	White
CAVAN	KILBRIDE DED	27052	White
CAVAN	KILCOGY DED	27053	White
CAVAN	KILGOLAGH DED	27055	White
CAVAN	KILL DED	27056	White
CAVAN	KILLINKERE DED	27059	White
CAVAN	KINAWLEY DED	27062	White
CAVAN	KNAPPAGH DED	27064	White
CAVAN	LARAH SOUTH DED	27066	White
CAVAN	LISAGOAN DED	27067	White
CAVAN	LISSANOVER DED	27068	White
CAVAN	LOUGHDAWAN DED	27069	White
CAVAN	MILLTOWN DED	27071	White
CAVAN	MUNTERCONNAUGHT DED	27074	White
CAVAN	PEDARAVOHERS DED	27075	White
CAVAN	REDHILL DED	27077	White
CAVAN	SKEAGH DED	27080	White
CAVAN	SPRINGFIELD DED	27081	White
CAVAN	TEMPLEPORT DED	27086	White
CAVAN	TERMON DED	27087	White
CAVAN	TIRCAHAN DED	27088	White
CAVAN	WATERLOO DED	27093	White
CLARE	ABBAY DED	37001	White
CLARE	AYLE DED	37003	White
CLARE	BALLYEIGHTER DED	37008	White
CLARE	BALLYNACALLY DED	37010	White
CLARE	CAHERMURPHY DED	37019	White
CLARE	CARRAN DED	37022	White
CLARE	CASTLETOWN DED	37025	White
CLARE	CLONDAGAD DED	37030	White
CLARE	CLOONADRUM DED	37031	White
CLARE	CLOONANAHA DED	37032	White
CLARE	CLOONEY DED	37034	White
CLARE	CLOONEY DED	37035	White
CLARE	CLOONTRA DED	37036	White

CLARE	COOLMEEN DED	37038	White
CLARE	COORACLARE DED	37040	White
CLARE	CREEGH DED	37044	White
CLARE	DERREEN DED	37047	White
CLARE	DOONBEG DED	37049	White
CLARE	DRUMELLIHY DED	37052	White
CLARE	FAHYMORE DED	37060	White
CLARE	FEAKLE DED	37061	White
CLARE	GLENINAGH DED	37065	White
CLARE	GLENMORE DED	37066	White
CLARE	KILFENORA DED	37075	White
CLARE	KILFIDDANE DED	37076	White
CLARE	KILLADYSERT DED	37079	White
CLARE	KILLANENA DED	37081	White
CLARE	KILLARD DED	37083	White
CLARE	KILLIMER DED	37087	White
CLARE	KILLOKENNEDY DED	37090	White
CLARE	KILLURAN DED	37092	White
CLARE	KILMIHIL DED	37093	White
CLARE	KILMURRY DED	37094	White
CLARE	KILSEILY DED	37100	White
CLARE	KILTANNON DED	37102	White
CLARE	KILTORAGHT DED	37104	White
CLARE	KNOCK DED	37106	White
CLARE	KNOCKNABOLEY DED	37107	White
CLARE	KNOCKNAGORE DED	37108	White
CLARE	KYLE DED	37109	White
CLARE	LACKAREAGH DED	37110	White
CLARE	LISCASEY DED	37112	White
CLARE	LOUGHEA DED	37115	White
CLARE	NEWGROVE DED	37127	White
CLARE	NOUGHAVAL DED	37129	White
CLARE	OUGHTMAMA DED	37132	White
CLARE	RATHBORNEY DED	37137	White
CLARE	RATHCLOONEY DED	37138	White
CLARE	TULLYGREEN DED	37152	White
CORK	ADRIGOLE DED	47002	White

CORK	AHIL DED	47008	White
CORK	ALLOW DED	47009	White
CORK	ARDAGH DED	47010	White
CORK	ARDFIELD DED	47011	White
CORK	ARDSKEAGH DED	47012	White
CORK	BALLINTEMPLE DED	47019	White
CORK	BALLYFOYLE DED	47026	White
CORK	BALLYHOOLAHAN DED	47029	White
CORK	BANTEER DED	47040	White
CORK	BARLEYHILL DED	47043	White
CORK	BARNACURRA DED	47044	White
CORK	BAURLEIGH DED	47045	White
CORK	BAWNCROSS DED	47046	White
CORK	BEALANAGEARY DED	47047	White
CORK	BEALOCK DED	47049	White
CORK	BENGOUR DED	47051	White
CORK	BOHERBOY DED	47055	White
CORK	BUTLERSTOWN DED	47059	White
CORK	CAHERDUGGAN DED	47063	White
CORK	CAHERMORE DED	47065	White
CORK	CANDROMA DED	47066	White
CORK	CANNAWAY DED	47067	White
CORK	CAPE CLEAR DED	47068	White
CORK	CASHEL DED	47078	White
CORK	CASTLECOOKE DED	47080	White
CORK	CASTLECOR DED	47081	White
CORK	CASTLEHAVEN SOUTH DED	47083	White
CORK	CASTLEMAGNER DED	47085	White
CORK	CHURCHTOWN DED	47091	White
CORK	CLONFERT EAST DED	47098	White
CORK	CLONFERT WEST DED	47099	White
CORK	CLONMEEN DED	47100	White
CORK	CLONMILT DED	47102	White
CORK	COOLCRAHEEN DED	47110	White
CORK	CRINNALOO DED	47118	White
CORK	CROOKHAVEN DED	47119	White

CORK	CURRYGLASS DED	47123	White
CORK	DANGAN DED	47124	White
CORK	DERRAGH DED	47125	White
CORK	DOUCE DED	47131	White
CORK	DROMINA DED	47139	White
CORK	DUNBEACON DED	47141	White
CORK	DUNMANUS DED	47144	White
CORK	FARRANBRIEN DED	47150	White
CORK	GLENGARRIFF DED	47160	White
CORK	GLENLARA DED	47161	White
CORK	GOLEEN DED	47163	White
CORK	GORTNASCREENY DED	47165	White
CORK	GORTNASKEHY DED	47166	White
CORK	GREENVILLE DED	47172	White
CORK	IMPHRICK DED	47174	White
CORK	INCH DED	47175	White
CORK	INCHIGEELAGH DED	47176	White
CORK	KILBERRIHERT DED	47182	White
CORK	KILBRIN DED	47184	White
CORK	KILCASKAN DED	47187	White
CORK	KILCATHERINE DED	47188	White
CORK	KILCORNEY DED	47191	White
CORK	KILCRONAT DED	47192	White
CORK	KILCULLEN DED	47193	White
CORK	KILDINAN DED	47195	White
CORK	KILLATHY DED	47201	White
CORK	KILMACDONAGH DED	47205	White
CORK	KILMEEN DED	47209	White
CORK	KILNAMANAGH DED	47213	White
CORK	WILLIAMSTOWN DED	47219	White
CORK	KNOCKATOOAN DED	47225	White
CORK	KNOCKAVILLY DED	47226	White
CORK	KNOCKMOURNE DED	47227	White
CORK	KNOCKNAGREE DED	47228	White
CORK	KNOCKTEMPLE DED	47233	White
CORK	LISCARROLL DED	47238	White

CORK	LISGOOLD DED	47240	White
CORK	MASHANAGLASS DED	47249	White
CORK	MEENS DED	47252	White
CORK	MILFORD DED	47256	White
CORK	MILLTOWN DED	47257	White
CORK	MOUNTRIVERS DED	47262	White
CORK	NAD DED	47266	White
CORK	NEWTOWN DED	47268	White
CORK	RAHALISK DED	47272	White
CORK	RATHBARRY DED	47274	White
CORK	RATHCOOL DED	47276	White
CORK	ROWLS DED	47285	White
CORK	SHEEPSHEAD DED	47289	White
CORK	SKAHANAGH DED	47292	White
CORK	SPRINGFORT DED	47297	White
CORK	TEERELTON DED	47301	White
CORK	TEMPLEBODAN DED	47302	White
CORK	TEMPLEMARTIN DED	47304	White
CORK	TEMPLEMARY DED	47305	White
CORK	TEMPLEMOLAGA DED	47307	White
CORK	TINCOORA DED	47311	White
CORK	TOORMORE DED	47312	White
CORK	TULLYLEASE DED	47314	White
DONEGAL	ALTNAPASTE DED	57001	White
DONEGAL	ARAN DED	57003	White
DONEGAL	ARDMALIN DED	57005	White
DONEGAL	ARDS DED	57006	White
DONEGAL	BALLINTRA DED	57007	White
DONEGAL	BALLINTRA DED	57008	White
DONEGAL	BALLYSHANNON URBAN DED	57012	White
DONEGAL	BINBANE DED	57014	White
DONEGAL	CARROWKEEL DED	57025	White
DONEGAL	CARTHAGE DED	57026	White
DONEGAL	CAVANGARDEN DED	57031	White
DONEGAL	CHURCH-HILL DED	57032	White
DONEGAL	CLIFF DED	57033	White

DONEGAL	CLOGHAN DED	57034	White
DONEGAL	CLOGHER DED	57036	White
DONEGAL	CREENASMEAR DED	57043	White
DONEGAL	CREESLOUGH DED	57044	White
DONEGAL	CROVEHY DED	57046	White
DONEGAL	DOE CASTLE DED	57052	White
DONEGAL	DUNAFF DED	57056	White
DONEGAL	DUNLEWY	57060	White
DONEGAL	EANYMORE DED	57061	White
DONEGAL	FANAD NORTH DED	57064	White
DONEGAL	FANAD WEST DED	57065	White
DONEGAL	FEDDYGLASS DED	57066	White
DONEGAL	FINTOWN DED	57068	White
DONEGAL	GARTAN DED	57069	White
DONEGAL	GLEN DED	57070	White
DONEGAL	GLENALLA DED	57071	White
DONEGAL	GLENLEHEEN DED	57076	White
DONEGAL	GORTAHORK DED	57081	White
DONEGAL	GRAFFY DED	57083	White
DONEGAL	GROUSEHALL DED	57086	White
DONEGAL	INISHKEEL DED	57090	White
DONEGAL	KILGOLY DED	57094	White
DONEGAL	KILLYMASNY DED	57099	White
DONEGAL	LAGHY DED	57104	White
DONEGAL	LETTERMACAWARD DED	57108	White
DONEGAL	LOUGH EASK DED	57110	White
DONEGAL	MAAS DED	57112	White
DONEGAL	MALIN DED	57116	White
DONEGAL	MALINBEG DED	57117	White
DONEGAL	MEENACLADY DED	57119	White
DONEGAL	MEENCARGAGH DED	57120	White
DONEGAL	PETTIGOE DED	57126	White
DONEGAL	SEACOR DED	57134	White
DONEGAL	ST JOHNSTOWN DED	57135	White
DONEGAL	TAWNAWULLY DED	57139	White
DONEGAL	TEMPLECARN DED	57140	White

DONEGAL	TEMPLEDOUGLAS DED	57141	White
DONEGAL	TERMON DED	57142	White
DONEGAL	TULLYNAUGHT DED	57146	White
GALWAY	ABBEGORMACAN DED	67003	White
GALWAY	ABBENVILLE DED	67004	White
GALWAY	ADDERGOOLE DED	67005	White
GALWAY	AHASCRAUGH DED	67006	White
GALWAY	AILLE DED	67007	White
GALWAY	BALLYCAHALAN DED	67022	White
GALWAY	BALLYGLASS DED	67023	White
GALWAY	BALLYMACWARD DED	67024	White
GALWAY	BALLYNAGAR DED	67027	White
GALWAY	BALLYNAKILL DED	67028	White
GALWAY	BEAGHMORE DED	67034	White
GALWAY	BELCLARE DED	67035	White
GALWAY	BENCORR DED	67037	White
GALWAY	BOYOUNAGH DED	67038	White
GALWAY	BRACKLAGH DED	67039	White
GALWAY	BULLAUN DED	67040	White
GALWAY	BUNOWEN DED	67041	White
GALWAY	CAHERMORE DED	67042	White
GALWAY	CAMUS DED	67044	White
GALWAY	CAPPALUSK DED	67045	White
GALWAY	CAPPARD DED	67046	White
GALWAY	CARROWNAGUR DED	67049	White
GALWAY	CARROWREVAGH DED	67050	White
GALWAY	CLARETUAM DED	67056	White
GALWAY	CLEGGAN DED	67058	White
GALWAY	CLIFDEN DED	67059	White
GALWAY	CLONBERN DED	67060	White
GALWAY	CLONTUSKERT DED	67063	White
GALWAY	CLOONBUR DED	67064	White
GALWAY	CLOONKEEN DED	67066	White
GALWAY	CLOONKEEN DED	67067	White
GALWAY	COLMANSTOWN DED	67068	White

GALWAY	CONG DED	67069	White
GALWAY	COOS DED	67071	White
GALWAY	CREGGS DED	67073	White
GALWAY	CUR DED	67076	White
GALWAY	CURRAGHMORE DED	67077	White
GALWAY	CUSHKILLARY DED	67078	White
GALWAY	DERREW DED	67080	White
GALWAY	DERRYGLASSAUN DED	67082	White
GALWAY	DOONBALLY DED	67086	White
GALWAY	DOONLOUGHAN DED	67087	White
GALWAY	DRUMKEARY DED	67090	White
GALWAY	DRUMMIN DED	67091	White
GALWAY	EYRECOURT DED	67095	White
GALWAY	FOXHALL DED	67096	White
GALWAY	GORUMNA DED	67102	White
GALWAY	GRANGE DED	67104	White
GALWAY	HILLSBROOK DED	67107	White
GALWAY	ILLION DED	67108	White
GALWAY	INISHMORE DED	67110	White
GALWAY	ISLAND DED	67111	White
GALWAY	KILBENNAN DED	67114	White
GALWAY	KILCHREEST DED	67115	White
GALWAY	KILCONIERIN DED	67117	White
GALWAY	KILCOONA DED	67119	White
GALWAY	KILCROAN DED	67120	White
GALWAY	KILCUMMIN DED	67121	White
GALWAY	KILCUMMIN DED	67122	White
GALWAY	KILLAAN DED	67123	White
GALWAY	KILLALLAGHTAN DED	67124	White
GALWAY	KILLEEN DED	67128	White
GALWAY	KILLIAN DED	67132	White
GALWAY	KILLIMOR DED	67133	White
GALWAY	KILLIMOR DED	67134	White
GALWAY	KILLINNY DED	67135	White
GALWAY	KILLORAN DED	67137	White
GALWAY	KILLOWER DED	67138	White

GALWAY	KILLURSA DED	67140	White
GALWAY	KILMEEN DED	67143	White
GALWAY	KILQUAIN DED	67145	White
GALWAY	KILREEKILL DED	67146	White
GALWAY	KILSHANVY DED	67147	White
GALWAY	KILTHOMAS DED	67150	White
GALWAY	KILTORMER DED	67151	White
GALWAY	KILTULLAGH DED	67152	White
GALWAY	KILTULLAGH DED	67153	White
GALWAY	KNOCKBOY DED	67155	White
GALWAY	LAURENCETOWN DED	67159	White
GALWAY	LEITRIM DED	67160	White
GALWAY	LETTERBRICKAUN DED	67161	White
GALWAY	LETTERFORE DED	67162	White
GALWAY	LETTERMORE DED	67163	White
GALWAY	LEVALLY DED	67164	White
GALWAY	LOUGHATORICK DED	67168	White
GALWAY	MARBLEHILL DED	67171	White
GALWAY	MILLTOWN DED	67173	White
GALWAY	MOAT DED	67174	White
GALWAY	MOUNTAIN DED	67177	White
GALWAY	MOUNTHAZEL DED	67178	White
GALWAY	MOYRUS DED	67182	White
GALWAY	OATFIELD DED	67183	White
GALWAY	OWENGOWLA DED	67186	White
GALWAY	PALLAS DED	67187	White
GALWAY	PORTUMNA DED	67188	White
GALWAY	RAFORD DED	67189	White
GALWAY	RAHEEN DED	67191	White
GALWAY	RINVYLE DED	67192	White
GALWAY	ROSS DED	67193	White
GALWAY	ROUNDSTONE DED	67194	White
GALWAY	SCREGG DED	67196	White
GALWAY	SELERNA DED	67197	White
GALWAY	SHANKILL DED	67198	White
GALWAY	SILLERNA DED	67199	White

GALWAY	TEMPLETOGHER DED	67206	White
GALWAY	TIAQUIN DED	67207	White
GALWAY	TOBERADOSH DED	67209	White
GALWAY	TOBERROE DED	67210	White
GALWAY	TURLOUGH DED	67214	White
GALWAY	TYNAGH DED	67215	White
GALWAY	WOODFORD DED	67216	White
KERRY	AGHADOE DED	77002	White
KERRY	ARDEA DED	77006	White
KERRY	BAHAGHS DED	77009	White
KERRY	BALLINSKELLIGS DED	77011	White
KERRY	BALLYBRACK DED	77013	White
KERRY	BALLYDUFF DED	77016	White
KERRY	BANAWN DED	77026	White
KERRY	BOOLTEENS DED	77031	White
KERRY	BRANDON DED	77032	White
KERRY	BREWSTERFIELD DED	77033	White
KERRY	BROSNA DED	77034	White
KERRY	CANUIG DED	77037	White
KERRY	CAPPAGH DED	77038	White
KERRY	CARKER DED	77039	White
KERRY	CARRAGH DED	77040	White
KERRY	CASTLEGREGORY DED	77043	White
KERRY	CHURCHTOWN DED	77047	White
KERRY	CLOGHANE DED	77048	White
KERRY	CLOON DED	77050	White
KERRY	CLOONTUBBRID DED	77051	White
KERRY	CLYDAGH DED	77052	White
KERRY	COOLIES DED	77053	White
KERRY	COOM DED	77054	White
KERRY	CORDAL DED	77055	White
KERRY	CRINNY DED	77056	White
KERRY	CURRAGHBEG DED	77057	White
KERRY	CURRAGHMORE DED	77058	White
KERRY	DARRYNANE DED	77060	White
KERRY	DAWROS DED	77061	White

KERRY	DEELIS DED	77062	White
KERRY	DERREEN DED	77063	White
KERRY	DERRIANA DED	77064	White
KERRY	DOOCARRIG DED	77066	White
KERRY	DROMMARTIN DED	77069	White
KERRY	DROMORE DED	77070	White
KERRY	DUAGH DED	77071	White
KERRY	DUNQUIN DED	77073	White
KERRY	DUNURLIN DED	77074	White
KERRY	EMLAGH DED	77075	White
KERRY	FLESK DED	77077	White
KERRY	GLANBEHY DED	77078	White
KERRY	GLANLEE DED	77079	White
KERRY	GLANLOUGH DED	77080	White
KERRY	GLANMORE DED	77081	White
KERRY	GLIN DED	77082	White
KERRY	GNEEVES DED	77083	White
KERRY	GREENANE DED	77084	White
KERRY	HEADFORT DED	77087	White
KERRY	INCH DED	77088	White
KERRY	KERRYHEAD DED	77090	White
KERRY	KILCUMMIN DED	77092	White
KERRY	KILFEIGHNY DED	77093	White
KERRY	KILFLYN DED	77095	White
KERRY	KILGARRYLANDER DED	77096	White
KERRY	KILGARVAN DED	77097	White
KERRY	KILGOBBAN DED	77098	White
KERRY	KILLINANE DED	77105	White
KERRY	KILMALKEDAR DED	77108	White
KERRY	KILMEANY DED	77109	White
KERRY	KILMURRY DED	77110	White
KERRY	KILNANARE DED	77111	White
KERRY	KILQUANE DED	77112	White
KERRY	KILSHENANE DED	77113	White
KERRY	KNOCKNAGASHEL DED	77118	White

KERRY	KNOCKNAHOE DED	77119	White
KERRY	LACK DED	77120	White
KERRY	LACKABAUN DED	77121	White
KERRY	LICKEEN DED	77124	White
KERRY	LOUGHBRIN DED	77130	White
KERRY	LOUGHCURRANE DED	77131	White
KERRY	MARHIN DED	77132	White
KERRY	MASTERGEEHY DED	77133	White
KERRY	MAUM DED	77134	White
KERRY	MILLBROOK DED	77135	White
KERRY	MOUNT EAGLE DED	77139	White
KERRY	NEWTOWNSANDES DED	77142	White
KERRY	NOHAVAL DED	77143	White
KERRY	RATHEA DED	77147	White
KERRY	RATHMORE DED	77148	White
KERRY	ROCKFIELD DED	77150	White
KERRY	ST FINAN'S DED	77154	White
KERRY	TAHILLA DED	77156	White
KERRY	TEERANEARAGH DED	77159	White
KERRY	TRIENEARAGH DED	77162	White
KERRY	VENTRY DED	77166	White
KILDARE	BALLITORE DED	87004	White
KILDARE	BALLYSHANNON DED	87010	White
KILDARE	CARRIGEEN DED	87021	White
KILDARE	CLONCURRY DED	87027	White
KILDARE	FEIGHCULLEN DED	87038	White
KILDARE	FONTSTOWN DED	87039	White
KILDARE	KILRUSH DED	87059	White
KILDARE	MOONE DED	87068	White
KILDARE	NARRAGHMORE DED	87072	White
KILDARE	SKERRIES DED	87083	White
KILDARE	USK DED	87088	White
KILKENNY	BALLEEN DED	97004	White
KILKENNY	BALLINAMARA DED	97005	White
KILKENNY	BALLINCREA DED	97006	White
KILKENNY	BALLYBEAGH DED	97007	White

KILKENNY	BALLYCALLAN DED	97008	White
KILKENNY	BALLYVOOL DED	97012	White
KILKENNY	BROWNSFORD DED	97017	White
KILKENNY	BURNCHURCH DED	97018	White
KILKENNY	CASTLEBANNY DED	97021	White
KILKENNY	CASTLEGANNON DED	97023	White
KILKENNY	COOLHILL DED	97030	White
KILKENNY	EARLSTOWN DED	97037	White
KILKENNY	FAMMA DED	97039	White
KILKENNY	FREAGHANA DED	97042	White
KILKENNY	INISTIOGE DED	97050	White
KILKENNY	JERPOINT WEST DED	97052	White
KILKENNY	KELLS DED	97054	White
KILKENNY	KILBRIDE DED	97056	White
KILKENNY	KILCOLUMB DED	97057	White
KILKENNY	KILKIERAN DED	97064	White
KILKENNY	KILMANAGH DED	97070	White
KILKENNY	LISDOWNEY DED	97073	White
KILKENNY	LISTERLIN DED	97074	White
KILKENNY	MOTHELL DED	97077	White
KILKENNY	MUCKALEE DED	97079	White
KILKENNY	PLEBERSTOWN DED	97084	White
KILKENNY	RATHEALY DED	97090	White
KILKENNY	SCOTSBOROUGH DED	97094	White
KILKENNY	THE ROWER DED	97100	White
KILKENNY	TISCOFFIN DED	97102	White
KILKENNY	TUBBRIDBRITTAIN DED	97104	White
KILKENNY	TULLAGHANBROGUE DED	97105	White
KILKENNY	TULLAROAN DED	97108	White
LAOISE	ARDERIN DED	107003	White
LAOISE	BALLYBROPHY DED	107010	White
LAOISE	BALLYLEHANE DED	107013	White
LAOISE	BALLYROAN DED	107015	White
LAOISE	BLANDSFORT DED	107017	White
LAOISE	BRISHA DED	107020	White

LAOISE	CAHER DED	107021	White
LAOISE	CARDTOWN DED	107024	White
LAOISE	CASTLECUFFE DED	107025	White
LAOISE	CLONMORE DED	107032	White
LAOISE	COOLRAIN DED	107034	White
LAOISE	CUFFSBOROUGH DED	107035	White
LAOISE	CULLAHILL DED	107036	White
LAOISE	DONORE DED	107041	White
LAOISE	DYSARTGALLEN DED	107045	White
LAOISE	EMO DED	107046	White
LAOISE	ERRILL DED	107047	White
LAOISE	GARRYMORE DED	107050	White
LAOISE	GRANTSTOWN DED	107053	White
LAOISE	KILCOKE DED	107055	White
LAOISE	KILDELLIG DED	107057	White
LAOISE	KYLE DED	107063	White
LAOISE	KYLE SOUTH DED	107064	White
LAOISE	LACKA DED	107065	White
LAOISE	MARYMOUNT DED	107067	White
LAOISE	MONEENALASSA DED	107069	White
LAOISE	NEALSTOWN DED	107075	White
LAOISE	RATHASPICK DED	107082	White
LEITRIM	AGHACASHEL DED	117001	White
LEITRIM	AGHAVAS DED	117004	White
LEITRIM	ANNADUFF DED	117006	White
LEITRIM	ARIGNA DED	117007	White
LEITRIM	BALLAGHAMEEHAN DED	117008	White
LEITRIM	BARNAMEENAGH DED	117010	White
LEITRIM	BREANDRUM DED	117013	White
LEITRIM	BUNNYBEG DED	117014	White
LEITRIM	CARRIGALLEN EAST DED	117016	White
LEITRIM	CARRIGALLEN WEST DED	117017	White
LEITRIM	CASTLEFORE DED	117019	White
LEITRIM	CLOONE DED	117022	White

LEITRIM	CLOVERHILL DED	117024	White
LEITRIM	CORRALA DED	117025	White
LEITRIM	CORRIGA DED	117026	White
LEITRIM	DRUMREILLY EAST DED	117031	White
LEITRIM	DRUMREILLY NORTH DED	117032	White
LEITRIM	DRUMREILLY SOUTH DED	117033	White
LEITRIM	DRUMREILLY WEST DED	117034	White
LEITRIM	DRUMSNA DED	117036	White
LEITRIM	FENAGH DED	117038	White
LEITRIM	GARADICE DED	117039	White
LEITRIM	GLENANIFF DED	117042	White
LEITRIM	GLENCAR DED	117044	White
LEITRIM	GLENFARN DED	117045	White
LEITRIM	GORTERMONE DED	117046	White
LEITRIM	GORTNAGULLION DED	117047	White
LEITRIM	GOWEL DED	117048	White
LEITRIM	GREAGHGLASS DED	117049	White
LEITRIM	KEELDRA DED	117051	White
LEITRIM	KESHCARRIGAN DED	117052	White
LEITRIM	KILLARGA DED	117054	White
LEITRIM	KILLYGAR DED	117055	White
LEITRIM	KILTUBBRID DED	117056	White
LEITRIM	KILTYCLOGHER DED	117057	White
LEITRIM	LISGILLOCK DED	117060	White
LEITRIM	MAHANAGH DED	117062	White
LEITRIM	MOHER DED	117065	White
LEITRIM	NEWTOWN GORE DED	117068	White
LEITRIM	OUGHTERAGH DED	117069	White
LEITRIM	RIVERSTOWN DED	117071	White
LEITRIM	ROWAN DED	117073	White
LEITRIM	SRAMORE DED	117074	White
LEITRIM	STRALONGFORD DED	117076	White
LEITRIM	YUGAN DED	117078	White

LIMERICK	ANGLESBOROUGH DED	127006	White
LIMERICK	ARDAGH DED	127007	White
LIMERICK	ARDPATRICK DED	127008	White
LIMERICK	BALLYBRICKEN DED	127017	White
LIMERICK	BALLYLANDERS DED	127020	White
LIMERICK	BALLYMACSHANEBOY DED	127021	White
LIMERICK	BALLYNABANOGE DED	127022	White
LIMERICK	BALLYNOE DED	127024	White
LIMERICK	BILBOA DED	127028	White
LIMERICK	BOOLA DED	127029	White
LIMERICK	BULGADEN DED	127033	White
LIMERICK	CAHER DED	127034	White
LIMERICK	CAHERCORNEY DED	127037	White
LIMERICK	CAHERELLY DED	127038	White
LIMERICK	CLEANGLASS DED	127045	White
LIMERICK	COOLRUS DED	127049	White
LIMERICK	CULLANE DED	127055	White
LIMERICK	DARRAGH DED	127057	White
LIMERICK	DOON WEST DED	127059	White
LIMERICK	DROMCOLLIHER DED	127061	White
LIMERICK	DUNMOYLAN EAST DED	127064	White
LIMERICK	DUNMOYLAN WEST DED	127065	White
LIMERICK	DUNTRYLEAGUE DED	127067	White
LIMERICK	EMLYGRENNAN DED	127068	White
LIMERICK	FEDAMORE DED	127069	White
LIMERICK	FLEANMORE DED	127071	White
LIMERICK	GALBALLY DED	127072	White
LIMERICK	GLENAGOWER DED	127075	White
LIMERICK	GLENBROHANE DED	127076	White
LIMERICK	GLENGORT DED	127077	White
LIMERICK	GLENSHARROLD DED	127078	White
LIMERICK	GRANGE DED	127081	White
LIMERICK	GREAN DED	127082	White

LIMERICK	GRISTON DED	127083	White
LIMERICK	HOSPITAL DED	127084	White
LIMERICK	KILBEHENY DED	127086	White
LIMERICK	KILFERGUS DED	127089	White
LIMERICK	KILFINNANE DED	127090	White
LIMERICK	KILFLYN DED	127092	White
LIMERICK	KILMEEDY DED	127095	White
LIMERICK	KILMOYLAN DED	127096	White
LIMERICK	KILTEELY DED	127100	White
LIMERICK	KNOCKAINY DED	127102	White
LIMERICK	KNOCKLONG DED	127103	White
LIMERICK	KNOCKNASCROW DED	127104	White
LIMERICK	LISMAKEERY DED	127107	White
LIMERICK	LOGHILL DED	127108	White
LIMERICK	MOHERNAGH DED	127110	White
LIMERICK	MOUNTCOLLINS DED	127112	White
LIMERICK	MOUNTPLUMMER DED	127113	White
LIMERICK	OOLA DED	127117	White
LIMERICK	PARTICLES DED	127119	White
LIMERICK	RATHRONAN DED	127125	White
LIMERICK	RIVERSDALE DED	127127	White
LIMERICK	ROOSKAGH DED	127129	White
LIMERICK	TEMPLEBREDON DED	127133	White
LIMERICK	TEMPLEGLENTAN DED	127134	White
LONGFORD	ARDAGH WEST DED	137005	White
LONGFORD	BALLINAMUCK EAST DED	137007	White
LONGFORD	COLUMBKILLE DED	137018	White
LONGFORD	CREEVY DED	137021	White
LONGFORD	DOORY DED	137025	White
LONGFORD	DRUMGORT DED	137026	White
LONGFORD	KILCOMMOCK DED	137036	White
LONGFORD	KILGLASS DED	137037	White
LONGFORD	MOYNE DED	137050	White
LONGFORD	MULLANALAGHTA DED	137051	White
LONGFORD	SONNAGH DED	137055	White
LOUTH	CREGGAN UPPER DED	147012	White

MAYO	ADDERGOOLE DED	157002	White
MAYO	AGHAGOWER NORTH DED	157003	White
MAYO	AGHAGOWER SOUTH DED	157004	White
MAYO	AGHAMORE DED	157005	White
MAYO	AILLEMORE DED	157006	White
MAYO	AN GEATA MOR THEAS DED	157007	White
MAYO	AN GEATA MOR THUAIDH DED	157008	White
MAYO	ARDNAREE NORTH DED	157010	White
MAYO	ATTYMASS EAST DED	157012	White
MAYO	ATTYMASS WEST DED	157013	White
MAYO	BALLINCHALLA DED	157019	White
MAYO	BALLYCASTLE DED	157022	White
MAYO	BALLYCROY NORTH DED	157023	White
MAYO	BALLYCROY SOUTH DED	157024	White
MAYO	BALLYNAGORAHER DED	157028	White
MAYO	BALLYOVEY DED	157029	White
MAYO	BALLYSAKEERY DED	157030	White
MAYO	BANGOR DED	157031	White
MAYO	BARROOSKY DED	157032	White
MAYO	BEKAN DED	157033	White
MAYO	BELDERGMORE DED	157034	White
MAYO	BELMULLET DED	157036	White
MAYO	BOHOLA DED	157037	White
MAYO	BRACKLOON DED	157038	White
MAYO	BUNAVEELA DED	157040	White
MAYO	BUNDORRAGHA DED	157041	White
MAYO	BURRISCARRA DED	157043	White
MAYO	CALLOW DED	157044	White
MAYO	CAPPAGHDUFF DED	157045	White
MAYO	CARAUN DED	157046	White

MAYO	CARROWMORE DED	157047	White
MAYO	CLARE ISLAND DED	157050	White
MAYO	CLOGHER DED	157052	White
MAYO	CLOGHER DED	157053	White
MAYO	CLOGHERMORE DED	157054	White
MAYO	CLOONMORE DED	157056	White
MAYO	COOLNAHA DED	157058	White
MAYO	COONARD DED	157059	White
MAYO	CORRAUN ACHILL DED	157060	White
MAYO	COURSE DED	157061	White
MAYO	CROAGHMOYLE DED	157062	White
MAYO	CROAGHPATRICK DED	157063	White
MAYO	CROSSMOLINA SOUTH DED	157066	White
MAYO	CUILDOO DED	157067	White
MAYO	CULNACLEHA DED	157068	White
MAYO	DALGAN DED	157069	White
MAYO	DEEL DED	157070	White
MAYO	DERRY DED	157071	White
MAYO	DERRYLOUGHAN DED	157072	White
MAYO	DOOCASTLE DED	157073	White
MAYO	DOOEGA DED	157074	White
MAYO	DRUMMIN DED	157075	White
MAYO	ERRIFF DED	157077	White
MAYO	FORTLAND DED	157078	White
MAYO	GARRYMORE DED	157079	White
MAYO	GLENAMOY DED	157080	White
MAYO	GLENCASTLE DED	157081	White
MAYO	GLENCO DED	157082	White
MAYO	GLENHEST DED	157083	White
MAYO	GOOLAMORE DED	157084	White
MAYO	HOLLYMOUNT DED	157085	White
MAYO	HOUNDWOOD DED	157086	White
MAYO	ISLANDEADY DED	157087	White
MAYO	KILBEAGH DED	157088	White
MAYO	KILCOMMON DED	157090	White
MAYO	KILFIAN EAST DED	157091	White

MAYO	KILFIAN SOUTH DED	157092	White
MAYO	KILFIAN WEST DED	157093	White
MAYO	KILGARVAN DED	157094	White
MAYO	KILGEEVER DED	157095	White
MAYO	KILKELLY DED	157096	White
MAYO	KILLALA DED	157097	White
MAYO	KILLAVALLY DED	157098	White
MAYO	KILLEDAN DED	157099	White
MAYO	KILMACLASSER DED	157100	White
MAYO	KILMAINE DED	157101	White
MAYO	KILMEENA DED	157102	White
MAYO	KILLSALLAGH DED	157104	White
MAYO	KILVINE DED	157106	White
MAYO	KNAPPAGH DED	157107	White
MAYO	KNOCK SOUTH DED	157109	White
MAYO	KNOCKADAFF DED	157110	White
MAYO	KNOCKNALOWER DED	157111	White
MAYO	LACKAN NORTH DED	157112	White
MAYO	LACKAN SOUTH DED	157113	White
MAYO	LETTERBRICK DED	157114	White
MAYO	MAYO DED	157118	White
MAYO	MEELICK DED	157119	White
MAYO	MOUNT FALCON DED	157120	White
MAYO	MUINGNABO DED	157121	White
MAYO	MUINGS DED	157122	White
MAYO	MURNEEN DED	157123	White
MAYO	NEALE DED	157124	White
MAYO	NEWBROOK DED	157125	White
MAYO	NEWPORT EAST DED	157126	White
MAYO	NEWPORT WEST DED	157127	White
MAYO	OWENBRIN DED	157128	White
MAYO	OWENNADORNAUN DED	157129	White
MAYO	PORTROYAL DED	157131	White
MAYO	RATHHILL DED	157132	White
MAYO	RATHOMA DED	157133	White
MAYO	ROSLEE DED	157134	White

MAYO	SALLYMOUNT DED	157135	White
MAYO	SHESKIN DED	157136	White
MAYO	SHRULE DED	157137	White
MAYO	SLIEVEMAHANAGH DED	157138	White
MAYO	SONNAGH DED	157140	White
MAYO	SRAHMORE DED	157142	White
MAYO	TAGHEEN DED	157145	White
MAYO	TAWNYNAGRY DED	157146	White
MAYO	TOOCANANAGH DED	157147	White
MAYO	TUMGESH DED	157149	White
MEATH	ARDBRACCAN DED	167002	White
MEATH	BECTIVE DED	167011	White
MEATH	CASTLEKEERAN DED	167016	White
MEATH	CLOGHBRACK DED	167019	White
MEATH	CLONMACDUFF DED	167020	White
MEATH	CROSSKEYS DED	167022	White
MEATH	DRUMCONDRA DED	167027	White
MEATH	KILLALLON DED	167047	White
MEATH	KILLARY DED	167048	White
MEATH	KILLEAGH DED	167049	White
MEATH	KILLYON DED	167051	White
MEATH	KILMORE DED	167054	White
MEATH	KNOCKLOUGH DED	167056	White
MEATH	LOUGHAN DED	167058	White
MEATH	MOYLAGH DED	167063	White
MEATH	RATHKENNY DED	167075	White
MEATH	RATHMORE DED	167076	White
MEATH	TROHANNY DED	167092	White
MONAGHAN	AGHABOG DED	177001	White
MONAGHAN	ANNAYALLA DED	177003	White
MONAGHAN	BELLATRIN DED	177009	White
MONAGHAN	BOCKS DED	177010	White
MONAGHAN	BROOMFIELD DED	177012	White
MONAGHAN	CARRICKASLANE DED	177014	White
MONAGHAN	CARRICKATEE DED	177015	White
MONAGHAN	CHURCH HILL DED	177021	White

MONAGHAN	CORMEEN DED	177026	White
MONAGHAN	CREEVE DED	177028	White
MONAGHAN	CREMARTIN DED	177029	White
MONAGHAN	CROSSALARE DED	177030	White
MONAGHAN	CURRIN DED	177031	White
MONAGHAN	DERRYGORRY DED	177033	White
MONAGHAN	DRUM DED	177035	White
MONAGHAN	DRUMCARROW DED	177037	White
MONAGHAN	DRUMGURRA DED	177038	White
MONAGHAN	DRUMMULLY DED	177040	White
MONAGHAN	GLASLOUGH DED	177046	White
MONAGHAN	GREAGH DED	177047	White
MONAGHAN	KILLEEVAN DED	177049	White
MONAGHAN	KILLYNENAGH DED	177051	White
MONAGHAN	KILMURRY DED	177053	White
MONAGHAN	LARAGH DED	177055	White
MONAGHAN	MULLYASH DED	177060	White
MONAGHAN	NEWBLISS DED	177061	White
MONAGHAN	SHANMULLAGH DED	177065	White
MONAGHAN	SHESKIN DED	177066	White
MONAGHAN	TEHALLEN DED	177069	White
OFFALY	AGHANCON DED	187001	White
OFFALY	BALLYCUMBER DED	187006	White
OFFALY	BRACKNAGH DED	187014	White
OFFALY	CLONBULLOGE DED	187020	White
OFFALY	CLONYGOWAN DED	187023	White
OFFALY	DOON DED	187030	White
OFFALY	ETTAGH DED	187039	White
OFFALY	GORTEEN DED	187044	White
OFFALY	KILCOLMAN DED	187049	White
OFFALY	KILLEIGH DED	187052	White
OFFALY	RAHEENAKEERAN DED	187071	White
OFFALY	RATHROBIN DED	187073	White
OFFALY	ROSCOMROE DED	187074	White
OFFALY	SEIRKIERAN DED	187076	White
OFFALY	TULLA DED	187085	White

ROSCOMMON	AGHAFIN DED	197001	White
ROSCOMMON	ALTAGOWLAN DED	197002	White
ROSCOMMON	ARTAGH SOUTH DED	197005	White
ROSCOMMON	AUGHRIM EAST DED	197009	White
ROSCOMMON	AUGHRIM WEST DED	197010	White
ROSCOMMON	BALLAGHADERREEN DED	197011	White
ROSCOMMON	BALLINLOUGH DED	197012	White
ROSCOMMON	BALLINTOBER DED	197013	White
ROSCOMMON	BALLYFORMOYLE DED	197016	White
ROSCOMMON	BUCKILL DED	197024	White
ROSCOMMON	CALTRAGH DED	197026	White
ROSCOMMON	CAMS DED	197027	White
ROSCOMMON	CARNAGH DED	197028	White
ROSCOMMON	CASTLETEHEEN DED	197034	White
ROSCOMMON	CLOONFLOWER DED	197037	White
ROSCOMMON	CLOONTEEM DED	197039	White
ROSCOMMON	CLOONYGORMICAN DED	197041	White
ROSCOMMON	CREEVE DED	197046	White
ROSCOMMON	CROGHAN DED	197049	White
ROSCOMMON	CROSSNA DED	197050	White
ROSCOMMON	DUNAMON DED	197055	White
ROSCOMMON	EDMONDSTOWN DED	197057	White
ROSCOMMON	KEADEW DED	197064	White
ROSCOMMON	KILBRIDE NORTH DED	197065	White
ROSCOMMON	KILBRYAN DED	197067	White
ROSCOMMON	KILGLASS SOUTH DED	197072	White
ROSCOMMON	KILLUMMOD DED	197076	White
ROSCOMMON	KILMORE DED	197078	White
ROSCOMMON	KILTULLAGH DED	197081	White
ROSCOMMON	LACKAN DED	197082	White
ROSCOMMON	LISMAHA DED	197085	White
ROSCOMMON	LOUGH ALLEN DED	197087	White
ROSCOMMON	OAKPORT DED	197092	White
ROSCOMMON	OGULLA DED	197093	White
ROSCOMMON	ROCKHILL DED	197094	White

ROSCOMMON	ROCKINGHAM DED	197095	White
ROSCOMMON	ROSMOYLAN DED	197099	White
ROSCOMMON	TAGHMACONNELL DED	197105	White
ROSCOMMON	TULSK DED	197109	White
ROSCOMMON	TURROCK DED	197112	White
SLIGO	ACHONRY WEST DED	207002	White
SLIGO	BALLINTOGHER WEST DED	207008	White
SLIGO	BREENCORRAGH DED	207016	White
SLIGO	BRICKLIEVE DED	207017	White
SLIGO	CASTLECONOR EAST DED	207024	White
SLIGO	CASTLECONOR WEST DED	207025	White
SLIGO	CLIFFONY SOUTH DED	207027	White
SLIGO	CLOONOGHILL DED	207029	White
SLIGO	CUILMORE DED	207033	White
SLIGO	DRUMCOLUMB DED	207039	White
SLIGO	GLENDARRAGH DED	207045	White
SLIGO	KILLADOON DED	207048	White
SLIGO	KILMACTRANNY DED	207052	White
SLIGO	KILSHALVY DED	207053	White
SLIGO	KILTURRA DED	207054	White
SLIGO	LAKEVIEW DED	207056	White
SLIGO	LEITRIM DED	207057	White
SLIGO	LISSADILL WEST DED	207061	White
SLIGO	MULLAGHERUSE DED	207063	White
SLIGO	RATHMACURKEY DED	207065	White
SLIGO	SHANCOUGH DED	207069	White
SLIGO	SKREEN DED	207070	White
SLIGO	STREAMSTOWN DED	207072	White
SLIGO	TEMPLEBOY NORTH DED	207074	White
SLIGO	TEMPLEBOY SOUTH DED	207075	White
SLIGO	TEMPLEVANNY DED	207076	White
SLIGO	TOBERPATRICK WEST	207079	White

	DED		
SLIGO	TOOMOUR DED	207080	White
TIPPERARY	ABINGTON DED	217001	White
TIPPERARY	AGHNAMEADLE DED	217002	White
TIPPERARY	ARDFINNAN DED	217006	White
TIPPERARY	BALLYCAHILL DED	217013	White
TIPPERARY	BALLYCARRON DED	217014	White
TIPPERARY	BALLYGRIFFIN DED	217017	White
TIPPERARY	BALLYLUSKY DED	217019	White
TIPPERARY	BORRISOKANE DED	217030	White
TIPPERARY	BRUIS DED	217034	White
TIPPERARY	BURNCOURT DED	217037	White
TIPPERARY	CARRIG DED	217043	White
TIPPERARY	CLOGHER DED	217049	White
TIPPERARY	CLOGHPRIOR DED	217051	White
TIPPERARY	CLONBEG DED	217053	White
TIPPERARY	CLONEEN DED	217054	White
TIPPERARY	COOLAGARRANROE DED	217060	White
TIPPERARY	CULLEN DED	217063	White
TIPPERARY	CURRAHEEN	217064	White
TIPPERARY	DERRYGRATH DED	217066	White
TIPPERARY	DOLLA DED	217067	White
TIPPERARY	EMLY DED	217072	White
TIPPERARY	FINNOE DED	217075	White
TIPPERARY	FOILNAMAN DED	217076	White
TIPPERARY	GARRANGIBBON DED	217078	White
TIPPERARY	GLENGAR DED	217079	White
TIPPERARY	GOLDEN DED	217081	White
TIPPERARY	GORTKELLY DED	217082	White
TIPPERARY	INCH DED	217088	White
TIPPERARY	KILBARRON DED	217090	White
TIPPERARY	KILCORAN DED	217095	White
TIPPERARY	KILLAVINOGE DED	217100	White
TIPPERARY	KILLEENASTEENA DED	217102	White
TIPPERARY	KILNANEAVE DED	217108	White
TIPPERARY	KILPATRICK DED	217110	White

TIPPERARY	LACKAGH DED	217117	White
TIPPERARY	LATTERAGH DED	217118	White
TIPPERARY	LATTIN DED	217119	White
TIPPERARY	MOYALIFF DED	217131	White
TIPPERARY	OUGHTERLEAGUE DED	217142	White
TIPPERARY	POYNTSTOWN DED	217144	White
TIPPERARY	RODUS DED	217151	White
TIPPERARY	SHRONELL DED	217153	White
TIPPERARY	TEMPLEDERRY DED	217155	White
TIPPERARY	TEMPLETOUHY DED	217158	White
TIPPERARY	TERRYGLASS DED	217159	White
TIPPERARY	THOMASTOWN DED	217160	White
TIPPERARY	TIMONEY DED	217163	White
TIPPERARY	TUBBRID DED	217167	White
TIPPERARY	TULLAGHMELAN DED	217168	White
TIPPERARY	TWO MILE BORRIS DED	217171	White
WATERFORD	BALLYDUFF DED	227004	White
WATERFORD	BALLYDURN DED	227005	White
WATERFORD	BALLYNAMULT DED	227013	White
WATERFORD	BALLYSAGGART MORE DED	227014	White
WATERFORD	BOHADOON DED	227015	White
WATERFORD	CARRIGCASTLE DED	227019	White
WATERFORD	CASTLERICHARD DED	227021	White
WATERFORD	CLASHMORE DED	227022	White
WATERFORD	COLLIGAN DED	227025	White
WATERFORD	COMERAGH DED	227026	White
WATERFORD	COUMARAGLIN DED	227027	White
WATERFORD	FEWS DED	227038	White
WATERFORD	FOX'S CASTLE DED	227039	White
WATERFORD	GARDENMORRIS DED	227040	White
WATERFORD	GEORGETOWN	227041	White
WATERFORD	GLEN DED	227042	White
WATERFORD	GRAIGNAGOWER DED	227045	White
WATERFORD	GURTEEN DED	227048	White

WATERFORD	KILBARRYMEADEN DED	227052	White
WATERFORD	KILCOCKAN DED	227053	White
WATERFORD	KILWATERMOY EAST DED	227062	White
WATERFORD	KNOCKAUNBRANDAUN DED	227065	White
WATERFORD	KNOCKMAHON DED	227066	White
WATERFORD	MOCOLLOP DED	227068	White
WATERFORD	MODELLIGO DED	227070	White
WATERFORD	MOUNTKENNEDY DED	227072	White
WATERFORD	RATHGORMUCK DED	227078	White
WATERFORD	ROSS DED	227082	White
WATERFORD	SESKINAN DED	227083	White
WATERFORD	TEMPLEMICHAEL DED	227087	White
WATERFORD	TINNASAGGART DED	227088	White
WESTMEATH	BALLYMORIN DED	237009	White
WESTMEATH	BALLYMORE DED	237013	White
WESTMEATH	BALLYNASKEAGH DED	237015	White
WESTMEATH	CHURCHTOWN DED	237026	White
WESTMEATH	CLONARNEY DED	237028	White
WESTMEATH	CLONLOST DED	237030	White
WESTMEATH	COLLINSTOWN DED	237031	White
WESTMEATH	COOLE DED	237032	White
WESTMEATH	COPPERALLEY DED	237034	White
WESTMEATH	DRUMRANEY DED	237038	White
WESTMEATH	FORE EAST DED	237044	White
WESTMEATH	FORE WEST DED	237045	White
WESTMEATH	GLORE DED	237049	White
WESTMEATH	HILLTOWN DED	237053	White
WESTMEATH	JAMESTOWN DED	237057	White
WESTMEATH	KILCUMNY DED	237060	White
WESTMEATH	KILLARE DED	237062	White
WESTMEATH	KILLULAGH DED	237066	White
WESTMEATH	KILPATRICK DED	237067	White
WESTMEATH	KNOCKDRIN DED	237071	White
WESTMEATH	MULTYFARNHAM DED	237081	White

WESTMEATH	RIVERDALE DED	237091	White
WESTMEATH	STONEHALL DED	237096	White
WESTMEATH	TAGHMON DED	237099	White
WESTMEATH	UMMA DED	237103	White
WESTMEATH	WOODLAND DED	237105	White
WEXFORD	ARDCOLM DED	247004	White
WEXFORD	BALLYHUSKARD DED	247016	White
WEXFORD	BALLYVALDON DED	247022	White
WEXFORD	CARNAGH DED	247030	White
WEXFORD	CASTLE ELLIS DED	247033	White
WEXFORD	DUNMAIN DED	247043	White
WEXFORD	INCH DED	247058	White
WEXFORD	KILNAHUE DED	247077	White
WEXFORD	LIMERICK DED	247084	White
WEXFORD	MONASEED DED	247088	White
WEXFORD	TAGHMON DED	247107	White
WEXFORD	WINGFIELD DED	247122	White
WICKLOW	ARKLOW RURAL DED	257003	White
WICKLOW	BALLINACOR DED	257007	White
WICKLOW	BALLINDERRY DED	257008	White
WICKLOW	BALLINGLEN DED	257010	White
WICKLOW	BALLINGUILE DED	257011	White
WICKLOW	BALLYARTHUR DED	257012	White
WICKLOW	BALLYBEG DED	257013	White
WICKLOW	COOLBALLINTAGGART DED	257023	White
WICKLOW	COOLBOY DED	257024	White
WICKLOW	CRONELEA DED	257026	White
WICKLOW	DONAGHMORE DED	257028	White
WICKLOW	DUNGANSTOWN EAST DED	257030	White
WICKLOW	DUNGANSTOWN SOUTH DED	257031	White
WICKLOW	DUNGANSTOWN WEST DED	257032	White
WICKLOW	EADESTOWN DED	257034	White
WICKLOW	ENNEREILLY DED	257035	White

WICKLOW	GLENDALOUGH DED	257037	White
WICKLOW	GLENEALY DED	257038	White
WICKLOW	HARTSTOWN DED	257040	White
WICKLOW	HOLLYWOOD DED	257041	White
WICKLOW	HUMEWOOD DED	257042	White
WICKLOW	IMAEI NORTH DED	257043	White
WICKLOW	IMAEI SOUTH DED	257044	White
WICKLOW	KILBALLYOWEN DED	257045	White
WICKLOW	KILBRIDE DED	257046	White
WICKLOW	KILLINURE DED	257049	White
WICKLOW	KILPIPE DED	257052	White
WICKLOW	KNOCKRATH DED	257053	White
WICKLOW	LUGGLASS DED	257055	White
WICKLOW	MONEYSTOWN DED	257057	White
WICKLOW	OLDTOWN DED	257060	White
WICKLOW	RATH DED	257063	White
WICKLOW	RATHDANGAN DED	257064	White
WICKLOW	TALBOTSTOWN DED	257069	White
WICKLOW	THE GRANGE DED	257070	White
WICKLOW	TOGHER DED	257073	White
WICKLOW	TROOPERSTOWN DED	257075	White

SCHEDULE 9

SERVICE LEVEL AGREEMENT

H3G National Broadband Scheme Wholesale Service Level Agreement

This WHOLESAL SERVICE LEVEL AGREEMENT (“**WSLA**”) between (“**H3G**”) and (“Wholesale End Users”) is to provide Wholesale Services under National Broadband Scheme.

H3G and the Wholesale End Users have agreed to enter into a contract for the supply by H3G to the Wholesale End Users of Wholesale Services upon the terms of the National Broadband Scheme: Terms and Conditions.

This WSLA is intended to identify and define the Wholesale Service and support levels provided to the Wholesale End Users by H3G.

This WSLA will be valid for the duration of the Wholesale End User Contract.

1. Wholesale Service Overview

This Wholesale Service Level Agreement covers access by Wholesale End Users’ to the H3GI SPConnect provisioning system. It also covers SLA provisions in National Broadband Scheme agreement in relation to Subscribers.

SPConnect is a Web Services (SOAP over HTTP) gateway that polices the submission of provisioning requests to H3GI from Wholesale End Users.

It authenticates the Wholesale End User to ensure it has the necessary log in details

It validates that the Wholesale End User has access to the provisioning service (API) it is requesting

It validates that the request relates to a subscriber of the Wholesale End User

Assuming the above three steps are successful it submits the provisioning request into the H3GI provisioning workflow

It provides a query mechanism to allow the client to determine the status of previously submitted requests

The Wholesale Service is a mobile data broadband service from H3GI, enabling customers to access internet at a minimum specification as agreed with DCENR and delivered by H3GI.

H3GI's has a target Service Availability of 99.995% achieved by use of the best available switching equipment together with diverse routing in the Network and integrated Network Management Centres operating 24 hours a day.

2. Wholesale End Users Summary of Commitments

2.1 Service Availability

Target Service Availability for connection to SPConnect service is 99.5% over a month.

Target Service Availability for network service is 98.5% over a Calendar Year.

2.2 Service Performance

Outlined in Table 1 SPConnect Service & Table 2 Wholesale Service is H3GI's minimum service specification against which service performance is measured.

	SPConnect Provisioning System	Target
1	Service Availability to SPConnect Provisioning System	99.5%

Table 1

	Wholesale Service	Target
1	Minimum Download speed – Minimum speed in Mbps that files are downloaded by a Subscriber from the Internet at the H3GI ISP.	
2	Maximum Contention Ratio – Maximum number of Subscribers that may be sharing the Minimum specification Retail Service at any one time.	36:1
3	Minimum Upload speed – speed in which files are uploaded by a Subscriber to the Internet at the Tenderers ISP.	200Kbps
4	Always On	Yes
5	Minimum Data Cap (Uncharged)	15GB - Data Cap (Uncharged) 12GB download , 3GB upload
6	Latency – The maximum round trip delay of a packet (ms) from the Subscriber to the Internet and back	~120ms

Table 2

2.4 Fault Restoration Times

Target Fault Restoration time for **SPConnect Provisioning System** is 4 hours

Target Restoration time is 4 hours from the date of notification of the fault by the Wholesale End User or earlier if fault is discovered by H3GI.

Outlined in Table 3 is H3GI's Target Restoration Times for faults on the SPConnect provisioning system.

Severity	H3GI SPConnect Problem Descriptions	Target Restoration Time
Critical	Complete loss of connectivity to SPConnect Provisioning System. H3GI will endeavour to resolve all critical faults A.S.A.P.	4 hours
Major	Significant degradation SPConnect Provisioning Service Failure of major non-critical functionality	8 hours

Minor	Minor degradation of SPConnect Provisioning Service	48 hours
Enquiry	A question about technical details, usage, billing or behaviour of an H3GI Service/Solution but service working normally	5 working days

Table 3

Target Response time for Service-Affecting Faults in relation to the Wholesale Service is 8 business Hours

Target Restoration time is 5 working days from the date of notification of the fault by Wholesale End Users or earlier if fault is discovered by H3GI.

Outlined in Table 4 is H3GI's Target Restoration Times for faults on the H3GI network

Severity	H3GI Generic Problem Description	Target Restoration Time
Critical	H3GI will endeavour to resolve all critical faults A.S.A.P. Complete loss of broadband service to all users within a specific area of National Broadband Scheme. Base station down or links from BS down – e.g. provider network issues i.e. critical outages A problem having severe impact on customer's service with no workaround available.	5 working days
Major	Significant degradation of service for all users Failure of major non-critical functionality	48 hours
Minor	Minor degradation of service to user.	48 hours
Enquiry	A question about technical details, usage, billing or behaviour of an H3GI Service/Solution but service working normally	5 working days

Table 4

2.5 Network Operating Centre

Outlined in Table 5 is H3GI's Network Operating Centre hours of operation and where network faults at a network level between H3GI and Wholesale End User can be reported.

Team	Hours of Operation	Day's available
Network Operating Centre	24 X 7	365 days a year

Table 5

2.6 Wholesale End Users Support

Outlined in Table 6 is H3GI's Wholesale End User 2nd level support hours of operation.

Team	Hours of Operation	Day's available
Wholesale End Users Support	24 X 7	365 days a year

Table 6**3. Service Rebates SPConnect**

Service rebates for failure to meet commitments in this SLA against availability of SPConnect provisioning system will be paid within 60 working days to Wholesale End Users against monthly service availability. Please see outlined in Table 7 service rebates

Services measured	Rebate %
SPConnect availability Guarantee (99.5%) Maximum Minutes of Total Service Outage per month (99.5% = 223 mins)	€500 per month

Table 7**4. Service Rebates Wholesale End Users Customers**

Service rebates for failure to meet commitments in this SLA will be paid within 60 working days to Wholesale End Users. Please see outlined in Table 8 service rebates for Service Performance and Service availability and Service Restoration

Services measured	Rebate % per subscriber
Service Performance meet specification as outlined in table 1	25% of the associated monthly Wholesale Tariff
Service Availability 98.5% per calendar year	50% of the associated monthly Wholesale Tariff
Service Restoration (Number of Working Days beyond Restoration time)	Rebate of associated monthly Wholesale Tariff
Less than 1	5%
Between 1 and 2	10%
Between 2 and 3	15%
More than 3	20%

Table 8**5. Exclusions from Rebates**

The calculations to determine Service Rebates will exclude the following circumstances.

- A *Force Majeure* event
- Problems or faults caused by a Subscribers equipment
- Problems or Faults caused by demonstrated Subscriber misuse of equipment or service
- SPConnect System

SCHEDULE 10
CREDIT CHECK PROCEDURES

Wholesale Credit & Risk Assessment Policy and Process

1. H3G will implement its credit and risk assessment process in a fair, reasonable and non-discriminatory manner. H3G recognises that wholesale customers' circumstances may vary and will operate its credit and risk assessment policy and activities in a sufficiently flexible manner.
2. New wholesale customers complete and submit the credit application form to the H3G Wholesale Account Manager.
3. Wholesale customers wishing to avail of wholesale services with H3G may be asked to provide specific information in order that their credit risk can be assessed. In addition, where an existing wholesale customer's payment performance or current financial performance would suggest a credit risk H3G has, acting reasonably, the right to undertake a review of their credit risk. Where H3G undertakes any such review, the customer shall be informed by H3G and afforded an opportunity to provide comments. The outcome of any such review will be notified by H3G to the wholesale customer along with details of how the review has been carried out and a transparency rationale for the outcome.
4. The H3G Wholesale Account Manager will request specific details from the new wholesale customer, including but not limited to:
 - the full company name and registered number
 - registered office address,
 - full list of directors including recent additions and removals,
 - expected bill level,
 - anticipated trading growth for service requested
 - summary narrative of existing business trading history,
 - and any other relevant information from either internal or external sources,

The above details will be submitted to the H3G Credit & Risk Assessment Department.

5. The H3G Credit & Risk Assessment Department will request references from a recognised credit assessment agency such as Dunn & Bradstreet or agency of equivalent standing. A credit report will provide detailed data to include, amongst other things, a risk indicator, a

credit limit and Statistical Scores to identify the likelihood of default by the wholesale customer. It is the wholesale customer's responsibility to query credit ratings directly with these credit agencies.

6. The Credit & Risk Assessment Department reviews the information provided as well as a report from the credit department for existing customers and assesses the following:
 - the structure and amount of liability
 - the company's financial position
 - where applicable, the credit history with H3G
 - any other public relevant information, e.g. media coverage, press releases, statements to stock exchange etc. The assessment is based on, but not limited to the above information.
7. The Credit & Risk Assessment Department then makes a recommendation on the requirement for security, deposit and/or the level of credit appropriate to the Senior Management Team in H3G.
8. A security and/or deposit will only be sought where credit vetting indicates a specific financial risk in the context of the wholesale customer's contract business value. Where a security is requested it shall be reasonable, proportionate and fair such that the level of security sought will be commensurate with the risk identified. Additionally, any request for security shall be one which is achievable.
9. The Senior Management team either signs off or modifies the credit recommendation.
10. Clarifications or additional information may be requested at anytime throughout the process.
11. The credit terms for the service is communicated to the wholesale customer and confirmed prior to contract signature.
12. The customer's credit performance is subsequently reviewed on a regular basis.

Notes:

H3G will on notification of any request for security and/or deposit offer to meet with the wholesale customer to explain how the credit assessment has been carried out and how any credit security or deposit levels have been set. Where H3G has relied on internal information for the purposes of setting a wholesale customer credit security level, H3G will make this information available to the Operator. Where H3G has relied on external information, H3G will identify external sources to the wholesale customer. Where the basis for, the level of and type of security and/or deposit is challenged by the wholesale customer, it will be subject to negotiation between H3G and the wholesale customer in the first instance. If agreement is not reached, the dispute resolution processes as set out in the Access Reference Offer will be invoked.

Application form wholesale customers for credit

General Information

Name of business
Billing address of business:
Telephone Number:
Fax Number:
Company website address:

Accounts Payable contact name:
Accounts payable e-mail address:
Accounts payable telephone number:
Accounts payable fax number:

Business Operations details

Date & Place of Incorporation (if relevant):
Company Registration Number:
Type of Business:
1. Proprietorship:
2. Partnership:
3. Limited company:
4. Subsidiary or associate company:
5. Public or privately held company:

Years at present address:
Years at previous address:

Please provide us with a brief summary of the company's operations and a description of the goods and services provided, and any other relevant information:

Please provide us with details of the services required from H3G (volumes and spend level):

Audited financial statements attached (for the most recent 2 years):

References Required

Please provide us with a minimum of three suppliers including their name, a contact person, address, phone number, fax number, web site address and e-mail address.

1.

Name of Company:	
Contact Name:	
Company Billing Address:	
Telephone:	
Fax number:	
Website address:	
E-mail Address:	

Brief description of products and/or services you purchase from this company and how much your average monthly bill would be:	
---	--

2.

Name of Company:	
Contact Name:	
Company Billing Address:	
Telephone:	
Fax number:	
Website address:	
E-mail Address:	
Brief description of products and/or services you purchase from this company and how much your average monthly bill would be:	

3.

Name of Company:	
Contact Name:	
Company Billing Address:	
Telephone:	
Fax number:	
Website address:	
E-mail Address:	
Brief description of products and/or services you purchase from this company and how much your average monthly bill would be:	

Bank Details Required

Name of Bank:
Address of Bank:
Bank Account Number:
Bank Sort Code:
Contact Name:
Contact telephone number:

Signed by:

Date: